



eunethta

EUROPEAN NETWORK FOR HEALTH TECHNOLOGY ASSESSMENT

GUIDELINE

COMPARATORS & COMPARISONS:

Direct and indirect comparisons

Adapted version (2015)

based on

"COMPARATORS & COMPARISONS: Direct and indirect comparisons" - February 2013

The primary objective of EUnetHTA JA1 WP5 methodology guidelines was to focus on methodological challenges that are encountered by HTA assessors while performing a rapid relative effectiveness assessment (REA) of pharmaceuticals.

The guideline "COMPARATORS & COMPARISONS: Direct and indirect comparisons" has been elaborated during JA1 by experts from HIQA, reviewed and validated by HAS and all members of WP5 of the EUnetHTA network; the whole process was coordinated by HAS.

During Joint Action 2 the wording in this document has been revised by WP7 in order to extend the scope of the text and recommendations from pharmaceuticals only to the assessment of all health technologies. Content and recommendations remained unchanged.

This guideline represents a consolidated view of non-binding recommendations of EUnetHTA network members and in no case an official opinion of the participating institutions or individuals.

Disclaimer: EUnetHTA Joint Action 2 is supported by a grant from the European Commission. The sole responsibility for the content of this document lies with the authors and neither the European Commission nor EUnetHTA are responsible for any use that may be made of the information contained therein.

Table of contents

Acronyms – Abbreviations	4
Summary and recommendations	5
Summary	5
Recommendations	6
1. Introduction	7
1.1. Definitions and general information	7
1.2. Context	7
1.2.1. Problem statement	7
1.2.2. Discussion (on the problem statement)	7
1.3. Scope/Objective(s) of the guideline	7
1.4. Relevant EUnetHTA documents	7
2. Summary of the analysed literature	8
2.1. Networks of evidence	8
2.2. Direct comparisons	9
2.2.1. Frequentist approach	9
2.2.2. Bayesian approach	10
2.3. Indirect comparisons	10
2.3.1. Unadjusted indirect comparison	10
2.3.2. Bucher's method of adjusted indirect comparison	11
2.4. Mixed treatment comparisons	11
2.4.1. Lumley's method of network meta-analysis	11
2.4.2. Bayesian mixed treatment comparison	11
2.4.3. Other approaches	12
2.5. Critical comparisons of techniques	12
2.5.1. Usage in practice	13
2.6. Additional considerations	13
2.6.1. Heterogeneity	13
2.6.2. Fixed and random effects	14
2.6.3. Publication bias	14
2.6.4. Outlier analysis and influential studies	15
2.6.5. Sensitivity to priors in a Bayesian approach	15
2.6.6. Dose-response issues in drug assessments	15
3. Discussion	16
4. Conclusion	18
Annexe 1. Methods of documentation and selection criteria	19
Sources of information	19
Data-bases	19
Websites	19
Guidelines, reports, recommendations already available	19
Books	19
Other	19
Bibliographic search strategy	20
Selection criteria	20
Annexe 2. Bibliography	21
Annexe 3. Literature search results	23

Acronyms – Abbreviations

IPD	individual patient data
MTC	mixed treatment comparison
NICE	National Institute for Health and Care Excellence
RCT	randomised controlled trial
REA	relative effectiveness assessment

Summary and recommendations

Summary

To make the best use of available evidence on the efficacy of a treatment, it is common to combine results from several randomised controlled trials (RCTs) in a meta-analysis. This guideline focuses on the methods available for treatment comparisons. Their strengths and limitations are discussed and recommendations are provided in order to support Relative Effectiveness Assessors in their activity. The planning stages of a systematic review are not covered here.

Direct comparisons combine the results of multiple head-to-head trials to generate a pooled estimate of the relative effectiveness of the two treatments using well described meta-analysis methods. These methods can be broadly split into frequentist and Bayesian approaches. When there is no prior expectation about what distributions parameters will take, Bayesian methods generate results that are approximately equivalent to frequentist methods. Bayesian methods can offer more sophisticated techniques than frequentist approaches to incorporate data from other sources such as observational studies. Sometimes insufficient data are available to reliably estimate the relative effectiveness of the two treatments or there may be a need to compare more than two treatments simultaneously in which case multiple treatment comparison methods are required.

Multiple treatment comparisons can be used to infer the relative effectiveness of two treatments in the absence of direct head-to-head evidence or through the combination direct and indirect evidence. A number of methods of multiple treatment comparison are available including Bucher's method of adjusted indirect comparison, Lumley's method of network meta-analysis, and Bayesian mixed treatment comparison (MTC). The comparisons available for analysis form a network of evidence. Depending on the method of multiple treatment comparison used, there may be restrictions on the type of evidence networks that can be analysed. Some methods of multiple treatment comparison produce a measure of inconsistency that can highlight where direct and indirect evidence is divergent. The application of multiple treatment comparison has become increasingly common since first being adopted in the last 1990's. Although Bucher's method of adjusted indirect comparison was initially the most popular methodology, its use has been surpassed by Bayesian MTC in recent years.

There are many issues that must be taken into account when conducting treatment comparisons. It is assumed that the relative effectiveness of a treatment is the same across all studies included in a meta-analysis. Heterogeneity across studies should be measured, reported and, if possible, explained. Study-level covariates can be used to partially account for heterogeneity using a meta-regression approach. If the observed relative effectiveness varies substantially across studies, then combining the results may not be appropriate. If there is substantial heterogeneity, then a random effects model may be preferable to a fixed effect model. Sources of bias such as publication bias may impact on results and attempts should be made to reduce the potential for bias to impact on the analysis. It is useful to assess whether there are influential or outlying observations and to test the impact of these studies using sensitivity analysis. The results of a meta-analysis using Bayesian methods can be sensitive to the choice of priors and sensitivity analysis should be considered to test alternative formulations of priors.

Direct comparison is generally thought to provide the best evidence of relative effectiveness and is in general recommended. However, the use of multiple treatment comparisons allows the consideration of a larger evidence base. When both direct and indirect evidence are available, it may be pragmatic to investigate both first separately and then pool the results. Although Bucher's method of adjusted indirect comparison is the most computationally straightforward of the multiple treatment methods, Bayesian MTC can be used to analyse very complex networks and can incorporate meta-regression to include study-level covariates. The choice of methodology is ultimately context specific and should be appropriate to the data available.

Recommendations

1. A systematic literature search is a pre-requisite to conducting a direct or indirect comparison. This must be documented according to existing guidelines. A comprehensive review will maximise the evidence base.
2. The application of direct or indirect comparisons relies on the assumption that only comparable studies should be combined. Studies that differ substantially in one or more key characteristics (e.g. participants, interventions, outcomes measured) should not be combined. Methods such as meta-regression that account for study level covariates may be used, although the power to detect effect differences is reduced.
3. The choice between a fixed and random effects model should be made based on the characteristics of the studies being analysed. Heterogeneity should be assessed and a clear justification for the choice of model must be provided. Where a random effects model is preferred, results from a fixed effect model can still be presented in special situations (e.g. few studies and where sample sizes vary considerably).
4. Potential sources of bias should be investigated, if identified (e.g. funnel plots for publication bias).
5. Attention should be given to determining the presence of outliers or influential observations that may have an undue impact on results. Sensitivity analysis should be used to determine the impact of those influential or outlying studies.
6. The choice between direct and indirect comparison is context specific and dependent on the question posed as well as the different evidence available. Where sufficient good quality head-to-head studies are available, direct comparisons are preferred as the level of evidence is high. Should substantial indirect evidence be available, then it can act to validate the direct evidence. When there is limited head-to-head evidence or more than two treatments are being considered simultaneously, the use of indirect methods may be helpful.
7. If both direct and indirect evidence are available, they can be evaluated separately. Attempts should be made to explain any discrepancies between the results obtained in terms of study characteristics. In the event of indirect results differing substantially from the direct evidence, there must be close scrutiny of the data, although there is no consensus in the literature on how to deal with these discrepancies.
8. Only adjusted methods of indirect comparison that maintain randomisation should be used. Unadjusted indirect comparisons are not recommended.
9. The choice of indirect comparison method relies on the network of available evidence. Preference should be given to the most transparent method available (i.e. one should favour Bucher's method of adjusted indirect comparison over MTC if the data permit its usage and the appropriate assumptions are satisfied).
10. An indirect comparison should only be carried out if underlying data from comparable studies are homogeneous and consistent, otherwise the results will not be reliable.
11. The assumptions made for indirect comparisons must be explicitly stated. Particular attention should be given to the homogeneity, similarity and consistency assumptions. A general assumption of indirect comparisons is that the relative effectiveness of a treatment is the same across all studies included in a meta-analysis.
12. When Bayesian methods are applied, the choice of the prior distributions should be justified and documented. In the case of non-informative priors, where alternative specifications exist they should be applied as part of a sensitivity analysis. When informative priors are used, the source of that data must be clearly documented and consideration given to testing the impact of using a non-informative prior in place of the informative prior.
13. The complexity of a model is not a measure of its accuracy or utility and preference is for the most parsimonious model whose assumptions can be justified.

1. Introduction

1.1. Definitions and general information

Direct comparison – the combination of multiple head-to-head trials to generate a pooled estimate of the relative effectiveness of the two treatments

Indirect comparison – the estimation of the relative effectiveness of two or more treatments in the absence of any head-to-head trials

Multiple treatment comparison – the estimation of the relative effectiveness of three or more treatments

Mixed treatment comparison – the simultaneous estimation of the relative effectiveness of three or more treatments using a combination of direct and indirect evidence

To compare two or more treatments, meta-analytic techniques are generally used to combine the results of multiple studies in an attempt to provide the best evidence base. A meta-analysis is the formal evaluation of the quantitative evidence from two or more studies addressing the same question. This most commonly involves the statistical combination of summary statistics from the various studies, but the term is sometimes also used to refer to the combination of raw data. Direct comparisons enable evidence synthesis based on multiple head-to-head trials. Where direct head-to-head evidence is lacking, indirect evidence can be used to supplement the relative effectiveness data from the direct comparisons available.

1.2. Context

1.2.1. Problem statement

"What methods for direct and indirect comparisons are used; are more advanced methods like Bayesian mixed treatment comparison used?"

1.2.2. Discussion (on the problem statement)

A variety of methods are available to conduct direct and indirect comparisons. Each method rests on a number of assumptions about the data used. The choice of method and associated assumptions may impact on the findings of a relative effectiveness assessment (REA).

1.3. Scope/Objective(s) of the guideline

This guideline is intended to describe the main methods of direct, indirect and mixed treatment comparison available in terms of the types of relationship they can model and the assumptions inherent in them. The guidelines are not intended to give a detailed understanding of the meta-analytic techniques described, but rather to explain the main strengths and weaknesses of the methodologies. The guideline discusses some common issues in meta-analysis that must be considered when interpreting results. Finally, the guideline provides a set of recommendations regarding the use of direct and indirect comparisons in a relative effectiveness assessment (REA).

1.4. Relevant EUnetHTA documents

Not applicable

2. Summary of the analysed literature

The relative effectiveness of two treatments is generally measured in a randomised controlled trial (RCT) setting. To make the best use of the available evidence base it is common to combine results from several trials in a meta-analysis. The process of combining RCT results involves some form of weighted average usually related to precision of the treatment effect estimation. In cases where two treatments are being compared, there is sometimes insufficient data available to reliably estimate the relative effectiveness of the two treatments in which case it may be possible to estimate the relative effectiveness using an indirect comparison.⁽¹⁾ For the purposes of this document it is presumed that sufficient data of acceptable quality are available to justify a meta-analysis. It is also assumed that the collection of the data contributing to the comparisons involved an exhaustive search of published and unpublished trials and a rigorous selection process based on the methodological quality of the trials.

2.1. Networks of evidence

The studies available for analysis form a network of evidence. Depending on the method of comparison used, there may be restrictions on the type of networks that can be analysed. For direct comparisons only a standard pair-wise meta-analysis can be used. Networks can include: a star pattern in which two or more treatments have a common comparator (e.g. A-B, C-B, D-B); a ladder where treatment comparisons appear in a sequence (e.g. A-B, B-C, C-D); a closed loop in which there is both direct and indirect evidence (e.g. A-B, A-C, C-B); or a complex combination of patterns such as a closed loop with a star (see Figure 1 for examples).⁽⁵⁾

Figure 1. Types of evidence network

Direct, or standard pair-wise, meta-analysis

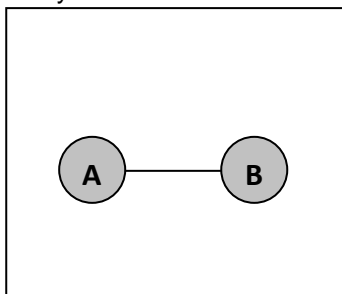

Indirect: simple star

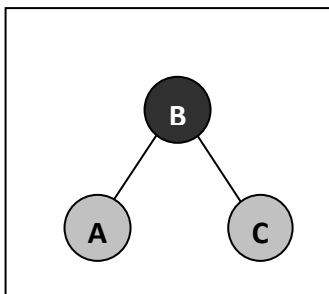

Indirect: star with pair-wise contrasts

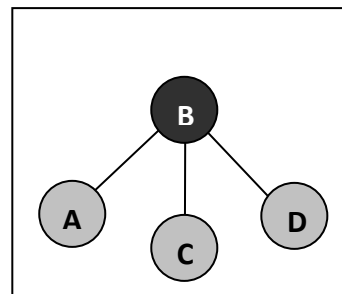

Indirect: ladder

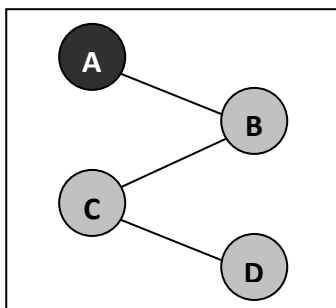

Direct and indirect: closed loop

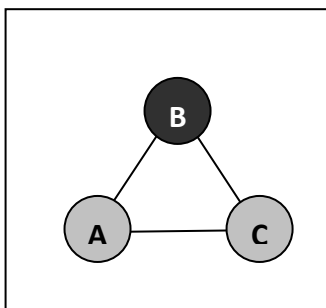

Direct and indirect: network with a closed loop

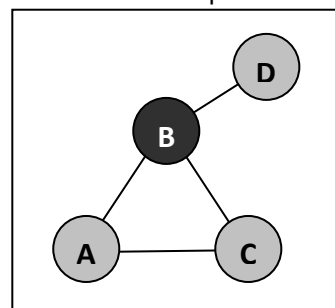

Direct and indirect: extended network

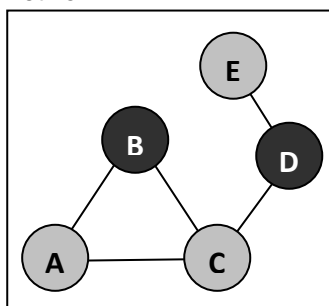

Direct and indirect: multi-loop

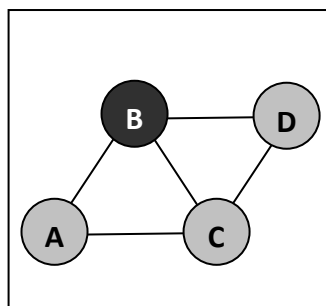
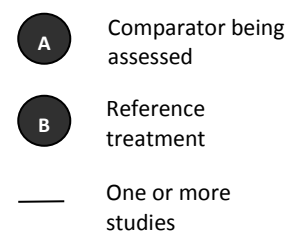
Legend

2.2. Direct comparisons

Direct comparisons involve a meta-analysis combining the results of multiple trials that all compare the treatment of interest to the same comparator (e.g. placebo). Meta-analysis involves the computation of a summary statistic for each trial followed by the combination of these studies into a weighted average.⁽²⁾ Outcomes can be expressed as binary or continuous data. The summary statistic can be odds ratios, risk ratios, risk differences, hazard ratios, differences in means or effect sizes (standardised mean differences). The same summary statistic must be computed for each study. Standard meta-analytic techniques are applied for direct comparisons. The primary decision in direct comparisons relates to the choice between fixed and random effects meta-analysis (see 3.6.2 below). Approaches to direct comparisons meta-analysis can be sub-divided into two methodologies: frequentist and Bayesian. The former are standard for direct comparisons primarily due to the ease of application and the variety of software packages available to apply them.

2.2.1. Frequentist approach

The frequentist methods available for direct comparison meta-analysis are divided into fixed and random effects methods. Fixed effect models include inverse variance, Mantel-Haenszel and Peto methods. Inverse variance methods can be used to pool binary or continuous data and weights are proportional to the inverse squared standard errors of the studies. Inverse variance methods are less reliable when data are sparse. The Mantel-Haenszel method provides more robust weighting when data are sparse and gives similar weights to inverse variance methods when data are not sparse, but may lack credibility when there are low numbers of events. The Mantel-Haenszel method can be applied to both binary and continuous data. The Peto method is used for odds ratios and can be extended for pooling time-to-event data. Peto's method has been shown to fail when treatment effects are very large and when the sizes of the trial arms are very unbalanced. The Peto method performs well when event rates are very low. Fixed effect methods tend to give small weights to small studies and large weights to large studies.

The most common random effects model is DerSimonian and Laird. A heterogeneity statistic is incorporated into the computation. When the heterogeneity statistic is small then the weights are equivalent to those given by the inverse variance method. With increasing heterogeneity the weights for each study become increasingly similar to each other. The consequences of this property are that small studies get weights more similar to larger studies and the confidence intervals around the pooled estimate become wider than would be observed in the fixed effect meta-analysis. The differences between fixed and random effects are discussed further in section 2.6.2.

For certain outcomes, such as rate ratios, a study with zero cases can be problematic for some weighting approaches such as the inverse-variance method. The common solution to this problem is to apply a continuity correction by adding a constant (typically 0.5) to the number of cases. The constant may be added to all studies, only to all studies with zero cases or only to all study arms with zero cases. The addition of a constant can be done irrespective of whether any of the studies have zero cases. The use of a continuity correction can impact on the significance and interpretation of results.⁽³⁾

While meta-analyses typically combine study level effect estimates, it is also possible to pool individual patient data (IPD) from studies. Use of individual data can improve the ability to include comparable subgroups or common outcomes which may not be reported in published studies. Analysis of patient data also enables more detailed time-to-event to be combined. The methods of IPD meta-analysis can be broadly classified into two groups: a one-step analysis, in which all patients are analysed simultaneously as though in a mega-trial, but with patients clustered by trial; or a two-step analysis in which the studies are analysed separately, but then summary statistics are combined using standard meta-analysis techniques. Hybrid methods are also available to combine individual patient data and aggregate study data. By modelling the individual risk across hundreds or thousands of patients, IPD meta-analyses generally have much higher power to detect differences in treatment effect than the equivalent aggregate data analyses that may have few studies. The main disadvantage of IPD meta-analysis is that it may not be possible to acquire individual level data from all relevant studies.

2.2.2. Bayesian approach

Bayesian methods for meta-analysis of direct comparisons are analogous to frequentist methods with the primary distinction being the use of prior distributions for the mean of the overall estimate, the means of the individual estimates of each study, and the between-study variance (for random effects models).(4) Priors provide an expectation of the distributions that parameters will take. Priors can be defined as non-informative or informative distributions. The former are used to make inferences that are not greatly affected by external information. The latter are based on some prior knowledge and have a stronger influence on the posterior distribution and hence on the estimate of relative effectiveness. The use of non-informative priors will generally result in effect estimates that are comparable to those in a frequentist approach. However, in some instances (e.g. expert opinion available in absence of collected data) it may be appropriate to form informative priors by way of other data. The use of informative priors is likely to generate results that depend on the choice of prior distribution and may differ to those from a frequentist approach.

The strength of Bayesian approaches in this context is that they can incorporate data from a wide variety of sources and are not restricted to using data from RCTs. For example, expert opinion can be used to elicit useful information that can then be incorporated into a Bayesian meta-analysis. While model flexibility is a strength of Bayesian methods, it is also a potential weakness as additional information may be incorporated in a biased or non-transparent manner. The use of informative priors must be accompanied by a justification and a clear description of how they were generated to maintain transparency.

2.3. Indirect comparisons

The need for indirect comparisons arises when comparing treatments A and B, but the only available evidence comes from studies comparing A to C and B to C. By using a common comparator, in this case treatment C, it is possible to generate an indirect comparison of treatments A and B. For a variety of reasons, placebo-controlled trials are commonly conducted in preference to head-to-head trials giving rise to the need for indirect comparisons.(5,15)

Methods for indirect comparisons have only been readily applied since the late 1990s and have quickly gained popularity. In unadjusted indirect comparisons, the results from individual arms of different trials are compared naïvely as if they were from a single controlled trial.(6) Adjusted indirect comparisons preserve randomisation and should always be used in preference to unadjusted methods.

2.3.1. Unadjusted indirect comparison

Unadjusted indirect comparisons combine study data as though they had come from a single large trial.(1) A weighted summary effect is computed for all study arms involving treatment A and is compared to a weighted summary effect for all study arms including treatment B. The two summary effects are then compared to determine the relative effectiveness of treatment A compared to treatment B.

The primary flaw of this approach is that it ignores the randomised nature of individual trials. Glenny et al. showed that when compared to direct estimates, unadjusted direct comparisons resulted in a large number of discrepancies in the significance and direction of relative effectiveness.(14) Although theoretically unbiased, this method clearly results in unpredictable results and is flawed by not acknowledging randomisation. As such this method of indirect comparison should not be used.

2.3.2. Bucher's method of adjusted indirect comparison

Bucher et al. presented an adjusted indirect method of treatment comparison that can estimate relative treatment effects for star pattern networks.⁽⁷⁾ This method is based on the odds ratio as the measure of treatment effect, although it can be trivially extended for other measures.⁽⁵⁾ This method is intended for situations where there is no direct evidence (e.g. we wish to compare treatments A and B, but the only evidence is through comparison with C). Certain more complex networks including closed loops can be analysed, but only in the form of pair-wise comparisons. As the method assumes independence between the pair-wise comparisons, it cannot readily be applied to multi-arm trials where this assumption fails.

Bucher's method of indirect comparison also assumes that the relative effectiveness of a treatment is the same across all trials used in the comparison. The assumption of constant efficacy requires all trials included in the analysis to be equivalent and attempting to measure the same treatment effect – that is, the results of one set of trials (A vs. B) should be generalisable to the other set of trials (A vs. C). Determining whether the assumption of generalisability holds is a subjective assessment based on a detailed review of the included studies in both comparisons. Were the sets of studies treating the same indications in comparable populations, and were they applying the common treatment in the same manner (e.g. dosing and frequency)?

2.4. Mixed treatment comparisons

A mixed treatment comparison combines direct and indirect evidence to determine the relative effectiveness of a treatment compared to two or more other treatments.

2.4.1. Lumley's method of network meta-analysis

The method of network meta-analysis proposed by Lumley allows the combination of both direct and indirect evidence.⁽⁸⁾ In the subsequent text, 'network meta-analysis' refers specifically to the Lumley method. This methodology requires the data to contain a closed loop structure. Depending on the complexity of the closed loop design, it is generally possible to compute relative effectiveness by a number of routes. It is possible to compute the amount of agreement between the results obtained when different linking treatments are used. This agreement forms the basis of an incoherence measure which is used to estimate the consistency of the network paths. Incoherence is used to compute the 95% confidence interval for the indirect comparison.

As with Bucher's adjusted indirect comparison method, it is assumed for network meta-analysis that the relative effectiveness of a treatment is the same across all trials used in the comparison. Network meta-analysis also does not automatically account for correlations that may exist between different effect estimates when they are obtained from a single multi-armed trial. In trials with more than two treatment arms, estimates of relative treatment effects will be correlated due to the structure of the network of evidence. For example, in a multi-arm placebo-controlled trial the comparison between any two treatments will be correlated with the comparison of each of those treatments with placebo. Accounting for this correlation is possible and can impact on the confidence interval around the relative treatment effect.

2.4.2. Bayesian mixed treatment comparison

Bayesian mixed treatment comparison (MTC) meta-analysis is a generalisation of standard pair-wise meta-analysis for A vs. B trials to more complex networks of evidence.⁽⁹⁾ Any combination of studies can be combined as long as all are connected in some way. Both direct and indirect evidence can be combined and there is no restriction to the number of arms in any given trial. Bayesian MTC facilitates simultaneous inference about all of the treatments included in the analysis, allowing estimation of effect estimates for all pair-wise comparisons and for treatments to be ranked according to relative effectiveness. Bayesian MTC is implemented in a Bayesian framework which provides more sophisticated methods for incorporating other sources of data such as observational studies or expert opinion. Methods have also been proposed and applied that combine Bayesian MTC and meta-regression which enables the incorporation of study-level covariates (e.g. setting, average patient characteristics, year of publication) in the Bayesian MTC framework as a means to reduce inconsistency although this adaptation has implications for compromised power.^(10, 11) Such covariates could potentially account for some between-study heterogeneity.⁽¹²⁾

As with the other approaches, a Bayesian MTC assumes that the true effect of a given treatment is the same in all trials included in the indirect comparison.(5) Bayesian MTC models assume that the correlation terms in the variance-covariance matrix have the same value and that the event rates, on the logit scale, follow a multivariate normal distribution. Being a Bayesian approach, there is scope for defining informative priors. While priors may be legitimately generated, it is critical that they are credible and clearly justified.

2.4.3. Other approaches

The confidence profile method provides a general framework for carrying out multi-parameter meta-analysis.(13) As well as incorporating trials with different treatment comparisons, it can encompass different designs, outcomes and measures of effect. The confidence profile method also allows explicit modelling of biases. Although this method is typically implemented as a fully Bayesian model, it can be formulated without prior distributions and fitted using maximum likelihood methods.(14) Where there is direct and indirect evidence available, cross-validators predictive checking can be used to determine evidence consistency.(5) In the case of drug-assessments, if different doses of the same pharmaceutical were studied, looking at dose-response relationships can also generate cross-validators information, provided the trial populations are comparable. The models available for this methodology are based on fixed-treatment effects although both fixed and random study-effects are possible. It is presumed that it is valid to combine the studies – that is the studies are measuring the same treatment effect.

Regression techniques can be used to combine trial data to evaluate relative effectiveness. Where the primary outcome is binary and data are available in the form of 2x2 frequency tables for each study, logistic regression can be used. Generalised linear mixed models (GLMMs) have also been proposed as a method of combining trial data in a regression framework.(14) GLMMs can be applied to individual level patient data which can be difficult to obtain. The advantage of regression techniques is the potential for including study level covariates that may be used to explain heterogeneity in the measured effects.

2.5. Critical comparisons of techniques

A number of reviews have compared the methods of direct, indirect and mixed treatment comparison outlined above. Comparisons have generally revolved around discussion of the principles and assumptions of each method followed by application to a sample dataset to compare the estimates generated by each method.

In terms of direct comparisons, frequentist and Bayesian approaches have been compared by Vandermeer et al.(15) The authors investigated six outcomes relating to treatment for chronic insomnia. The two approaches produced very similar results, although the Bayesian approach yielded wider credible intervals (analogous to frequentist confidence intervals). The two approaches are essentially equivalent when non-informative priors are used. However, in a given context there may be multiple ways to define non-informative priors and sensitivity to the choice of priors was noted for certain parameters.

Glenny et al. used a sample data set of 15 trials to compare a variety of methods for indirect comparison.(14) They compared Bucher's method of adjusted indirect comparison (inverse variance, fixed and random effects), meta-regression (weighted linear and random effects), logistic regression and mixed models (that combined fixed and random effects). With the exception of the mixed models, the other seven models gave comparable effect estimates and confidence bounds. The mixed models, however, produced slightly lower estimates and larger confidence intervals.

Methods of indirect treatment comparison were compared by Edwards et al.(16) Using a single common comparator for indirect comparison is relatively inefficient in mathematical terms. Four times the amount of data are required to provide the same precision around an indirect comparison as would be required for a direct comparison. Furthermore, the use of a single comparator limits the number of RCTs available for inclusion in the analysis as only three treatments can be compared in any single analysis. Bias may also be introduced by 'lumping' individual treatments into convenient categories (e.g. drug classes) to achieve maximum statistical power with the available RCTs.

Bayesian MTC and Bucher's adjusted indirect comparison method were compared by O'Regan et al. across a range of network types. (17) They found that in most cases the two methods produced similar results although there were a limited number of instances where they produced estimates that differed in direction. For single and multi loop networks the results were very similar although it was remarked that results could be expected to differ for general single loop networks on the grounds that the Bayesian MTC approach is

based on all available information. For star shaped networks the results were equivalent and, given the ease of applying Bucher's method of adjusted indirect comparison, it may be preferable over the more complex Bayesian MTC.

Wells et al. compared Bucher's method of adjusted indirect comparison, network meta-analysis, the confidence profile method and Bayesian MTC.(5) Each method was applied to sample data followed by a discussion of the relative merits of each approach. Bucher's method of adjusted indirect comparison was extended to apply to relative risks, hazard ratios, risk differences and mean differences. The method was also adapted to be applicable to ladder networks. The authors conclude that although Bucher's adjusted indirect comparison method cannot always be applied, the simplicity of its application and interpretation is considered highly advantageous.

2.5.1. Usage in practice

As part of the originally conducted literature search during JA1, on the basis of abstracts it was possible to classify papers that applied Bucher's adjusted indirect comparisons, Lumley's network meta-analysis and Bayesian MTC. There were also a number of studies that applied Bayesian methodology that could not be classified as either network meta-analysis or MTC. There were 40 studies identified that applied Bayesian MTC, making it the single most popular methodology. There were 27 and 24 studies applying network meta-analysis and Bucher's method of adjusted indirect comparison, respectively. Other Bayesian methods were used in 18 studies. One paper was identified that applied a naïve approach to indirect comparison. Lumley's network meta-analysis and Bayesian MTC appear to be gaining popularity, while Bucher's adjusted indirect comparison method appears to no longer be commonly used. The total number of published multiple comparisons is increasing year on year peaking at 34 in 2009, the last full year included.

Song et al. conducted a survey of systematic reviews published between 2000 and 2007 that used multiple comparisons.(6) They observed a year on year increase in the number of published papers that contained indirect comparisons. By 2007 the most common method was Bucher's method of adjusted indirect comparison. The results of the survey included an assessment of methodological problems found in published indirect comparisons. These problems include: poor understanding of underlying assumptions; use of flawed or inappropriate methods; inadequate comparison and inappropriate combination of direct and indirect evidence; incomplete literature search; and poor assessment of trial similarity. While methods for indirect comparison are widely available and frequently applied, they are often used without understanding and in situations where it may be inappropriate. In some instances, insufficient detail is provided in the published study to fully evaluate whether the findings are either accurate or valid. Further work by this group has found that significant inconsistency between direct and indirect comparisons may be more prevalent than previously observed.(18)

A systematic review by Schöttker et al. investigated multiple comparisons published between 1999 and 2008.(19) They found Bucher's method of adjusted indirect comparisons to be the most common methodology but noted the increasing popularity of Bayesian MTC. They also looked at the number of discrepancies in results where both direct and indirect comparisons were used. Discrepancies were highest when unadjusted indirect comparisons were used, followed by meta-regression, Bucher's adjusted indirect comparison and Bayesian MTC. Discrepancies were most commonly found where the assumption of between-study homogeneity did not hold.

2.6. Additional considerations

The application of meta-analysis is multi-faceted and requires giving consideration to a wide range of issues that are not necessarily related to the methodology being used. Some of the key issues are outlined below.

2.6.1. Heterogeneity

It is assumed that the relative effectiveness of a treatment is the same across all studies included in a meta-analysis – that is, we assume similarity of studies. If the results of the studies are very different then we observe heterogeneity and combining the results may not be appropriate.(20) Three broad forms of heterogeneity have been identified: statistical, where effect estimates vary more than expected by chance alone; clinical, due to differences in patient populations or study settings; and methodological, arising from differences in study design and analysis.(21) It is possible to test for heterogeneity to provide evidence for whether or not the study results differ greatly. This is not an optimal way to assess heterogeneity and, where

significant heterogeneity is observed, it is critical to closely examine the studies being combined. There can be many causes of heterogeneity such as variations in study design, study subjects, setting, geographic location, and outcome measures. In some instances it will be possible to partially explain heterogeneity between studies by differences such as those listed above. Even if the variability can be explained, there must still be a decision whether or not to proceed with the meta-analysis and whether to consider subgroup analyses. A subgroup analysis can involve including studies that are considered equivalent according to a more narrowly defined set of criteria (e.g. age range of study participants).

Inconsistency is a measure of how closely a network of evidence fits together. A measure of inconsistency can be calculated within Bayesian MTC while Lumley's method of network analysis estimates incoherence which is analogous to inconsistency, but is calculated in a different manner. In mixed treatment comparisons, consistency between direct and indirect evidence is assumed. That is, if direct evidence suggests that treatment A is better than treatment B, then that evidence should not be contradicted by the indirect evidence. Depending on the amount of evidence available, indirect comparisons can sometimes generate estimates of relative effectiveness via two or more different paths. In comparing treatments A and B, the relative effectiveness should be similar whether derived via common comparator C or D. A statistically significant difference in the estimate of relative effectiveness would indicate inconsistency. A difference in direction of relative effectiveness, even if not statistically significant, would also raise concerns about consistency. In a multiple treatment comparison involving both direct and indirect evidence, the evidence network can become very complex with many comparisons based on only one or two studies. With increasing complexity and greater numbers of treatments the prospect of inconsistency increases. There is also a power trade-off between the number of pair-wise comparisons and the number of studies included in the analysis – too many comparisons with too few studies and the analysis may be underpowered to detect true differences.⁽¹⁰⁾ Understanding the cause or source of inconsistency in a complex network can be difficult to determine, which raises questions about how elaborate an evidence network should be in order to be accepted for analysis. In the context of a multiple treatment comparison, the presence of heterogeneity may mask inconsistency. If relevant heterogeneity is present, it is not advisable to proceed with a multiple treatment comparison.

2.6.2. Fixed and random effects

In fixed effect meta-analyses the true effect of treatment is assumed to be the same in each study. Use of a fixed effect model therefore follows from the assumption that variability between studies is entirely due to chance. In a random effects meta-analysis the treatment effect in each study is assumed to vary around an overall average treatment effect.⁽²⁾ As the random effects model assumes a different underlying effect for each study it tends to result in wider confidence intervals than the fixed effect model.⁽²⁰⁾ When the reported effect sizes are homogeneous the fixed and random effects approaches yield very similar results. The choice between random and fixed effect models is context specific and the decision is often made following an assessment of heterogeneity. Examples of common heterogeneity measures include I^2 and Q . Substantial heterogeneity suggests use of a random effects model but also raises the question of whether the studies are actually comparable. The use of random effects has implications for the interpretation of results and the distribution of effect estimates should be discussed.⁽¹¹⁾ A measure of heterogeneity should be reported to support the choice between a fixed and random effects model. If relevant or explicable heterogeneity is present then using a fixed effect model would not be correct. In such instances a fixed effect model should only be presented in special situations (e.g. few studies and where sample sizes vary considerably).

2.6.3. Publication bias

The issue of publication bias arises due to journals being more likely to publish studies showing beneficial effects of treatments while equally valid studies showing no significant effect remain unpublished.⁽²²⁾ The consequence of this bias is that a meta-analysis will show a spurious significant effect. Publication bias may be detectable using funnel plots or regression techniques but these are not particularly powerful techniques.⁽²³⁾ Asymmetry in a funnel plot may indicate publication bias or it may be a reflection of how comprehensive the search strategy has been. English language bias and citation bias are forms of publication bias in which studies with negative findings are more likely to appear in non-English language publications and are less likely to be cited, respectively. It is of critical importance that the search strategy element of the systematic review is as comprehensive as possible and that clinical trial registers are searched, where possible. The presence of publication bias can impact on any meta-analysis irrespective of the methodology used (i.e. direct, indirect or mixed treatment comparison).

2.6.4. Outlier analysis and influential studies

The results of a meta-analysis may be overly influenced by one or a small number of studies. Similarly, some studies may be outliers in a statistical sense. Outliers and influential studies are not synonymous: an outlier need not necessarily be influential and an influential study need not be an outlier. A first step is to visually inspect a forest plot to identify any unusual data points or where the pooled estimate appears to be driven by a single or small number of studies. In conventional direct comparisons, metrics such as Cook's distance can be used to identify influential studies and standardised study-level residuals can be used to identify outliers.(24) In Bayesian MTC, visual inspection of QQ-plots has been used to identify outliers.(9) Sensitivity analysis techniques can be used to determine the impact of influential studies and outliers on the results of a meta-analysis. For example, an analysis can be conducted with and without a particular study to determine the impact of that study on the results.(25) It is also useful to characterise outliers and gain an understanding of why they might be different from other studies.

2.6.5. Sensitivity to priors in a Bayesian approach

A common criticism of Bayesian techniques is that they rely on the use of priors for key parameters. A point of criticism is that priors are subjectively chosen. In reality, most Bayesian analyses employ vague or non-informative priors. However, even with a non-informative prior, assumptions are made about the distribution of that prior and often there are alternative formulations available so the use of sensitivity analysis is important.(26) For a number of example analyses, Wells et al. found that the Bayesian methods were insensitive to the prior chosen for the mean, but were sensitive to the prior chosen for the between study variance.(5) They also found that the between study prior sensitivity was directly related to the number of studies included in the analysis. A sensitivity analysis in this context is not trivial as there will be a number of parameters with specified priors and there may be several potential priors for each parameter. In the event that conclusions on the effects size are affected by the choice of prior then additional evidence will have to be gathered to justify the choice of priors.

2.6.6. Dose-response issues in drug assessments

For addressing the issue of REA of pharmaceuticals, it is also important to define which doses of pharmaceuticals have been compared and to address the question of whether the dose-response relationships of the individual pharmaceuticals allow extrapolation to other doses. In sponsored trials there is also a risk that the comparator treatment may be administered at a sub-optimal dose or frequency to show the active treatment in a more favourable light. For trials to be considered comparable it is therefore important to assess the comparability of treatment regimens across the included trials.

3. Discussion

Direct comparisons require a number of head-to-head studies to estimate the relative effectiveness of two treatments. Should a third treatment be considered, unless sufficient studies were three-arm trials, a direct comparison is no longer possible and a multiple treatment comparison would be required.(11) The ability to consider more complex networks of evidence is an advantage of indirect methods, but this benefit may increase the potential of introducing inconsistencies. It is recommended that comparisons should be based on a focused research question with careful attention to ensuring that only comparable studies are included.

In presenting the indirect comparison method, Bucher contended that direct methods should be used whenever possible in preference to indirect methods.(7) However, more recent developments suggest that the combination of direct and indirect evidence may achieve a more accurate and comprehensive analysis.(27) The use of indirect and mixed treatment comparisons highlights the importance of a thorough literature search and identification of all relevant studies. Multiple treatment comparisons can be sensitive to data, particularly when there may be only one study for a given pair-wise comparison.(28) Furthermore, there is a power trade-off between the number of pair-wise comparisons and the number of studies included in the analysis – too many comparisons with too few studies and the analysis may be underpowered to detect true differences.(10)

Irrespective of methodology, a key principle of meta-analysis is that only comparable studies should be combined.(29) For both direct and indirect comparisons, it is critical that only comparable studies are selected for inclusion in the analysis. As an adjunct to studies being comparable, the results of the studies should be consistent. That is to say, if A is more effective than B and B is more effective than C, then it is anticipated that A will be more effective than C. Such a relationship is not a given and there is the potential for inconsistencies to arise in indirect comparisons. Within Bayesian MTC there is the possibility of assessing the level of inconsistency between direct and indirect evidence.(30) Lumley's network meta-analysis enables the estimation of incoherence in the evidence network which is analogous to inconsistency.(8) When direct and indirect evidence differ or inconsistencies arise then the first step is to assess the similarity of participants and interventions across studies.(1) In terms of study population or interventions, the studies providing direct evidence may be sufficiently different from those providing indirect evidence to account for inconsistency in the results. That is to say, there may be systematic heterogeneity between direct and indirect evidence which may explain the conflicting results. In the event of such identifiable differences, presenting both combined and individual results of direct and indirect comparisons is the most appropriate approach. It should be borne in mind that the results of indirect comparisons are not valid if relevant inconsistency is present.

In contrast to the frequentist approach, the output of a Bayesian approach can be interpreted in terms of probabilities.(26) Thus Bayesian approaches facilitate the computation of useful measures such as the probability of treatment superiority, the probability that a clinically meaningful difference exists, or the probability of clinical equivalence.(31) It is possible to compute the probability that a given treatment is the best amongst those analysed and how the other treatments are ranked, which constitutes information useful clinically and to decision makers.(32) Bayesian methods also facilitate predicting the utility of conducting additional head-to-head studies.(26) The benefits to the decision maker of Bayesian outputs need to be weighed against the increased complexity of the modelling and expertise required in applying these methods.

Indirect comparisons can be affected by the same forms of bias as direct comparisons but these forms of bias can arise in subtle ways. For example, studies of new treatments often find them to be more effective than existing treatments even though the benefit may be spurious.(33) In an indirect comparison the chronology of studies will impact on the relative effectiveness of each treatment and it may be difficult to tease out what is genuine and what may be spurious even with the aid of measures of inconsistency. With a direct comparison a cumulative meta-analysis, for example, could be used to reveal changes in relative effectiveness over time. In applying indirect comparisons, a thorough assessment of inconsistency or incoherence must be carried out and reported. Song et al. suggest that Bucher's adjusted indirect comparison method could be used as a means to cross-examine evidence from direct comparisons as it may be subject to different forms of bias.(34) Hence the two approaches, direct and indirect comparison, may act to validate each other's results. The use of indirect and mixed treatment comparisons highlights the importance of a thorough literature search and identification of all relevant studies, including observational studies and unpublished data.

The mixed treatment comparison incorporating direct evidence could be considered the 'gold standard' approach of carrying out indirect comparisons.(15) Of the indirect comparison methods, where the available

evidence supports the use of either Bucher's method of adjusted indirect comparison or Bayesian MTC, the former approach offers the most in terms of transparency and relative ease of application.(5;35) Bayesian MTC has gained popularity and has greater flexibility with regard to the network of evidence available but these benefits must be counterbalanced by the difficulty in applying this methodology and the scope for incorrect specification of the model. The application of Bayesian MTC involves many choices that may alter the conclusions of the analysis but the justifications for those choices may seem somewhat arbitrary.(36) The complexity of the Bayesian MTC models renders them less advantageous than Bucher's method of adjusted indirect comparison or network meta-analysis when the latter methods can be applied.

4. Conclusion

To maximise the evidence on the relative effectiveness of an intervention it is common to combine results from several randomised controlled trials (RCTs) in a meta-analysis. Direct comparisons combine the results of multiple head-to-head trials whereas indirect comparisons can infer the relative effectiveness in the absence of direct head-to-head evidence. Irrespective of the methodology used, a meta-analysis must be preceded by a properly conducted and transparent systematic literature review.

Direct methods use well known meta-analysis techniques which may be either frequentist or Bayesian although the former are more common. Methods of indirect comparison are a more recent development and still evolving. Bucher's adjusted indirect comparison method is being supplanted by the Bayesian MTC approach. Both of these methods generate similar results when applied to the same data but Bayesian MTC can be used to analyse far more complex networks of evidence and can include study-level covariates. It has been suggested by a number of commentators that the least complex model that can be applied in a given analysis is generally preferable.

There is no consensus on the best approach to comparisons, particularly when both direct and indirect evidence are available. In the case of a head-to-head comparison where sufficient good quality studies are available for a direct comparison, an indirect comparison may not be necessary. However, where the direct evidence is limited, then combining the direct with indirect evidence is advantageous. Alternatively, if a number of treatments are being considered simultaneously, then indirect or multiple treatment comparison may be helpful. It may also be desirable to carry out direct and mixed treatment comparison separately to determine the impact of incorporating indirect evidence. Alternatively, if a number of treatments are being considered simultaneously, then a multiple treatment comparison is preferable. When both direct and indirect evidence exists, it is important to investigate inconsistencies between the direct and indirect evidence and to attempt to account for the discrepancies.

Bucher's method of adjusted indirect comparison, Lumley's method of network meta-analysis and Bayesian MTC are acceptable methods for indirect comparisons in the context of REA.

Bayesian methods are advantageous for a number of reasons (e.g. they can incorporate additional sources of evidence and they produce output that is inherently interpretable by decision makers). However, these advantages must be weighed against the sometimes increased complexity of the Bayesian models and a potential lack of transparency.

When conducting a treatment comparison, irrespective of methodology used there are a number of additional issues to consider: heterogeneity; fixed and random effects models; the presence of bias; influential observations and outliers; and, in a Bayesian context, to investigate the sensitivity of results to the choice of priors.

In making a comparison between two or more treatments, it is critical that the reported relative effectiveness is an accurate reflection of reality. That accuracy can only be achieved by using the best evidence available synthesised using the most appropriate methods. The choice of methodology is context specific and should be based on an objective assessment of the quality and quantity of the direct and indirect evidence, the comparability of the selected studies, and of the fundamental assumptions in the different models. The complexity of a model is not a measure of its accuracy or utility and preference is for the most parsimonious model.

Annexe 1. Methods of documentation and selection criteria (related to original guideline elaboration in JA1)

Keywords that will be used for the bibliographic research:

- Meta-analysis
- Meta-regression
- Direct comparison
- Direct treatment comparison
- Indirect comparison
- Unadjusted indirect comparison
- Adjusted indirect comparison
- Mixed treatment comparison
- Indirect treatment comparison
- Multiple treatment comparison
- Network meta-analysis
- Bayesian

Sources of information

Data-bases

MEDLINE
MEDLINE via OVID
DARE
Cochrane Database of Systematic Reviews
CADTH/CEDAC
EBSCOhost

Websites

National Guideline Clearinghouse
National Institute for Health and Clinical Excellence
ISPOR
Pharmaceutical Benefits Advisory Committee (PBAC)
Centre for Reviews and Dissemination, University of York
University of Bristol
Haute Autorité de Santé (HAS)

Guidelines, reports, recommendations already available

Gartlehner G, Moore CG. Direct versus indirect comparisons: A summary of the evidence. *International Journal of Technology Assessment in Health Care*, 24:2 (2008), 170–177.

Wells GA, Sultan SA, Chen L, Khan M, Coyle D. *Indirect Evidence: Indirect Treatment Comparisons in Meta-Analysis*. Ottawa: Canadian Agency for Drugs and Technologies in Health; 2009.

Books

The topic is relatively new; no relevant books were identified.

Other

Google and Google Scholar
ScienceDirect
Wiley-InterScience
Hand searching of references cited in relevant documents
The Cochrane Collaboration
The Cochrane Methodology Register

Bibliographic search strategy

Direct comparisons are generally dealt with by way of standard meta-analytic techniques that are well-documented. Indirect comparisons are a more recent development and most applications have occurred since the paper of Bucher et al. in 1997. For PubMed, the search was limited to the period "last ten years". In EBSCO the search was limited to 2000 to 2010 (inclusive). In both cases the search was limited to English language publications and human subjects.

Database searches used the following search strategy:

("network meta-analysis" OR "mixed treatment" OR "multiple treatment" OR "multiple comparison" OR "cross-trial") AND (meta-analysis OR systematic) OR ((indirect comparison OR "direct comparison") AND (meta-analysis OR systematic))

Selection criteria

Reports, papers and other guidance documents were assessed on the basis of whether they described, applied or assessed methods of direct and indirect treatment comparisons. Documents that only mentioned methods, but did not describe, apply or assess them were discarded after being checked for useful references. Documents describing new methods provided keywords and were also used to identify subsequent citing documents that then either applied or assessed those new methods. Documents that applied methods were used to determine the scope of application, utility and possible limitations of those methods. Finally, documents that assessed methods were used to compare methods directly and to elicit recommendations.

The full bibliography is provided in Annexe 2 and is split into two – methodological/review articles and application articles. The former articles were used to form opinion and recommendations. The latter articles were not reviewed in depth, but were used to determine the frequency with which the different methods are applied as a marker of acceptability and diffusion into common practice.

Annexe 2. Bibliography

- (1) Gartlehner G, Moore CG. Direct versus indirect comparisons: A summary of the evidence. *International Journal of Technology Assessment in Health Care* 2008;24(02):170-7.
- (2) *Systematic Reviews in Health Care: Meta-analysis in Context*. London: BMJ Publishing Group; 2007.
- (3) Diamond GA, Bax L, Kaul S. Uncertain Effects of Rosiglitazone on the Risk for Myocardial Infarction and Cardiovascular Death. *Annals of Internal Medicine* 2007; 147:578-581.
- (4) Vandermeer BW, Buscemi N, Liang Y, Witmans M. Comparison of meta-analytic results of indirect, direct, and combined comparisons of drugs for chronic insomnia in adults: a case study. *Medical Care* 2007 Oct;45(10 Supl 2):S166-S172.
- (5) Wells GA, Sultan SA, Chen L, Khan M, Coyle D. *Indirect Evidence: Indirect Treatment Comparisons in Meta-Analysis*. Ottawa: Canadian Agency for Drugs and Technologies in Health; 2009.
- (6) Song F, Loke YK, Walsh T, Glenny AM, Eastwood AJ, Altman DG. Methodological problems in the use of indirect comparisons for evaluating healthcare interventions: survey of published systematic reviews. *BMJ* 2009;338:b1147.
- (7) Bucher HC, Guyatt GH, Griffith LE, Walter SD. The results of direct and indirect treatment comparisons in meta-analysis of randomized controlled trials. *Journal of Clinical Epidemiology* 1997 Jun;50(6):683-91.
- (8) Lumley T. Network meta-analysis for indirect treatment comparisons. *Statistics in Medicine* 2002;21(16):2313-24.
- (9) Lu G, Ades AE. Combination of direct and indirect evidence in mixed treatment comparisons. *Statistics in Medicine* 2004;23(20):3105-24.
- (10) Cooper NJ, Sutton AJ, Morris D, Ades AE, Welton NJ. Addressing between-study heterogeneity and inconsistency in mixed treatment comparisons: Application to stroke prevention treatments in individuals with non-rheumatic atrial fibrillation. *Statistics in Medicine* 2009;28(14):1861-81.
- (11) Sutton A, Ades AE, Cooper N, Abrams K. Use of Indirect and Mixed Treatment Comparisons for Technology Assessment. *Pharmacoeconomics* 2008 Jun;26(9):753.
- (12) Nixon RM, Bansback N, Brennan A. Using mixed treatment comparisons and meta-regression to perform indirect comparisons to estimate the efficacy of biologic treatments in rheumatoid arthritis. *Statistics in Medicine* 2007;26(6):1237-54.
- (13) Sutton AJ, Higgins JPT. Recent developments in meta-analysis. *Statistics in Medicine* 2008;27:625-50.
- (14) Glenny AM, Altman DG, Song F, Sakarovitch C, Deeks JJ, D'Amico R, et al. Indirect comparisons of competing interventions. *Health Technology Assessment* 2005;9(26).
- (15) Haute Autorité De Santé. *Indirect comparisons: methods and validity*. HAS; 2009.
- (16) Edwards SJ, Clarke MJ, Wordsworth S, Borrill J. Indirect comparisons of treatments based on systematic reviews of randomised controlled trials. *International Journal of Clinical Practice* 2009;63(6):841-54.
- (17) O'Regan C, Ghement I, Eyawo O, Guyatt GH, Mills EJ. Incorporating multiple interventions in meta-analysis: an evaluation of the mixed treatment comparison with the adjusted indirect comparison. *Trials* 2009;10(86).
- (18) Song F, Xiong T, Parekh-Bhurke S, Loke YK, Sutton AJ, Eastwood AJ, Holland R, Chen YF, Glenny AM, Deeks JJ, Altman DJ. Inconsistency between direct and indirect comparisons of competing interventions: meta-epidemiological study. *BMJ* 2011; 343:d4909.

- (19) Schöttker B, Lühmann D, Boukhemair D, Raspe H. Indirekte Vergleiche von Therapieverfahren. (German). *GMS Health Technology Assessment* 2009 Jan;5:1-13.
- (20) Egger M, Smith GD, Phillips AN. Meta-analysis: Principles and procedures. *BMJ* 1997;315:1533-7.
- (21) Ades AE, Sculpher M, Sutton A, Abrams K, Cooper N, Welton N, et al. Bayesian Methods for Evidence Synthesis in Cost-Effectiveness Analysis. *PharmacoEconomics* 2006 Jan;24(1):1-19.
- (22) Egger M, Smith GD, Schneider M, Minder C. Bias in meta-analysis detected by a simple, graphical test. *BMJ* 1997;315:629-34.
- (23) Peters JL, Sutton AJ, Jones DR, Abrams KR, Rushton L. Comparison of Two Methods to Detect Publication Bias in Meta-analysis. *JAMA* 2006;295:676-80.
- (24) Harbord RM, Whiting P. metandi: Meta-analysis of diagnostic accuracy using hierarchical logistic regression. *Stata Journal* 2009;9(2):211-29.
- (25) Cooper NJ, Sutton AJ, Lu G, Khunti K. Mixed Comparison of Stroke Prevention Treatments in Individuals With Nonrheumatic Atrial Fibrillation. *Arch Intern Med* 2006 Jun 26;166(12):1269-75.
- (26) Jansen JP, Crawford B, Bergman G, Stam W. Bayesian Meta-Analysis of Multiple Treatment Comparisons: An Introduction to Mixed Treatment Comparisons. *Value in Health* 2008;11(5):956-64.
- (27) Caldwell DM, Ades AE, Higgins JPT. Simultaneous comparison of multiple treatments: combining direct and indirect evidence. *BMJ* 2005 Oct 15;331(7521):897-900.
- (28) Hawkins N, Scott DA, Woods BS, Thatcher N. No Study Left Behind: A Network Meta-Analysis in Non Small-Cell Lung Cancer Demonstrating the Importance of Considering All Relevant Data. *Value in Health* 2009;12(6):996-1003.
- (29) Caldwell DM, Gibb DM. Validity of indirect comparisons in meta-analysis. *The Lancet* 2007;369(9558):270.
- (30) Dias S, Welton NJ, Caldwell DM, Ades AE. Checking consistency in mixed treatment comparison meta-analysis. *Statistics in Medicine* 2010;29(7-8):932-44.
- (31) Brophy JM, Joseph L. Medical Decision Making with Incomplete Evidence--Choosing a Platelet Glycoprotein IIb/IIIa Receptor Inhibitor for Percutaneous Coronary Interventions. *Med Decis Making* 2005 Mar 1;25(2):222-8.
- (32) Ioannidis JPA. Integration of evidence from multiple meta-analyses: a primer on umbrella reviews, treatment networks and multiple treatments meta-analyses. *CMAJ* 2009 Oct 13;181(8):488-93.
- (33) Salanti G, Higgins JPT, Ades AE, Ioannidis JPA. Evaluation of networks of randomized trials. *Statistical Methods In Medical Research* 2008 Jun;17(3):279-301.
- (34) Song F, Harvey I, Lilford R. Adjusted indirect comparison may be less biased than direct comparison for evaluating new pharmaceutical interventions. *Journal of Clinical Epidemiology* 2008 May;61(5):455-63.
- (35) Nuijten M, Mickisch G. SUN vs BEV[thorn]IFN in first-line mRCC therapy: no evidence for a statistically significant difference in progression-free survival. *Br J Cancer* 2010;102(1):232-3.
- (36) Pocock SJ. Safety of drug-eluting stents: demystifying network meta-analysis. *The Lancet* 2007 Dec 22;370(9605):2099-100.

Annexe 3. Literature search results (related to original guideline elaboration in JA1)

Methodological and review articles:

- (1) Ades AE, Sculpher M, Sutton A, Abrams K, Cooper N, Welton N, et al. Bayesian methods for evidence synthesis in cost-effectiveness analysis. *Pharmacoeconomics* 2006;24(1):1-19.
- (2) Ballesteros J. Orphan comparisons and indirect meta-analysis: a case study on antidepressant efficacy in dysthymia comparing tricyclic antidepressants, selective serotonin reuptake inhibitors, and monoamine oxidase inhibitors by using general linear models. *Journal Of Clinical Psychopharmacology* 2005 Apr;25(2):127-31.
- (3) Bender R, Bunce C, Clarke M, Gates S, Lange S, Pace NL, et al. Attention should be given to multiplicity issues in systematic reviews. *Journal Of Clinical Epidemiology* 2008 Sep;61(9):857-65.
- (4) Caldwell D. Making sense of umbrella reviews [abstract]. Sao Paulo, Brazil 2010 p. 96-7.
- (5) Caldwell DM, Ades AE, Higgins JP. Simultaneous comparison of multiple treatments: combining direct and indirect evidence. *BMJ* 2005 Oct 15;331(7521):897-900.
- (6) Caldwell DM, Gibb DM, Ades AE. Validity of indirect comparisons in meta- analysis. *Lancet* 369[9558], 270. 27-1-2007.
Ref Type: Generic
- (7) Carey TS, Williams JW, Jr., Melvin C, Oldham J, Goodman F. Best practices: comparing medication treatments in mental health: drug class reviews and policy challenges. *Psychiatric Services (Washington, D C)* 2007 Jun;58(6):746-8.
- (8) Centre for Reviews and Dissemination. Indirect comparisons of competing interventions (Structured abstract). 2005.
- (9) Chou R, Fu R. Validity of indirect comparisons in meta- analysis. *Lancet* 369[9558], 271. 27-1-2007.
Ref Type: Generic
- (10) Chung H, Lumley T. Graphical exploration of network meta-analysis data: the use of multidimensional scaling. *Clinical Trials (London, England)* 2008;5(4):301-7.
- (11) Cipriani A, Furukawa TA, Churchill R, Barbui C. Validity of indirect comparisons in meta- analysis. *Lancet* 369[9558], 270-271. 27-1-2007.
Ref Type: Generic
- (12) Cooper NJ, Sutton AJ, Ades AE, Welton NJ. Addressing between-study heterogeneity and inconsistency in mixed treatment comparisons: application to stroke prevention treatments for Atrial Fibrillation patients. Oral presentation at the 16th Cochrane Colloquium: Evidence in the era of globalisation; 2008 Oct 3-7; Freiburg, Germany [abstract]. *Zeitschrift fur Evidenz, Fortbildung und Qualitat im Gesundheitswesen* 2008;102(Suppl VI):21.
- (13) Cooper NJ, Sutton AJ, Morris D, Ades AE, Welton NJ. Addressing between-study heterogeneity and inconsistency in mixed treatment comparisons: Application to stroke prevention treatments in individuals with non-rheumatic atrial fibrillation. *Statistics In Medicine* 2009 Jun 30;28(14):1861-81.
- (14) Dias S, Welton NJ, Caldwell DM, Ades AE. Checking consistency in mixed treatment comparison meta-analysis. *Stat Med* 2010 Mar 30;29(7-8):932-44.
- (15) Donegan S, Tudur SC, Gamble C, Williamson P. Methodological and reporting quality of indirect comparisons. Poster presentation at the 16th Cochrane Colloquium: Evidence in the era of globalisation; 2008 Oct 3-7; Freiburg, Germany [abstract]. *Zeitschrift fur Evidenz, Fortbildung und Qualitat im Gesundheitswesen* 2008;102(Suppl VI):92.
- (16) Eckermann S, Coory M, Willan AR. Indirect comparison: relative risk fallacies and odds solution. *Journal Of Clinical Epidemiology* 2009;62(10):1031-6.
- (17) Edwards SJ, Clarke MJ, Wordsworth S, Borrill J. Indirect comparisons of treatments based on systematic reviews of randomised controlled trials. *International Journal of Clinical Practice* 2009 Jun;63(6):841-54.
- (18) Falissard B, Zylberman M, Cucherat M, Iazard V, Meyer F. Real medical benefit assessed by indirect comparison. *Therapie* 2009 May;64(3):225-32.
- (19) Glenny AM, Altman DG, Song F, Sakarovitch C, Deeks JJ, D'Amico R, et al. Indirect comparisons of competing interventions. *Health Technology Assessment (Winchester, England)* 2005 Jul;9(26):1.
- (20) Griffin S, Bojke L, Main C, Palmer S. Incorporating direct and indirect evidence using bayesian methods: an applied case study in ovarian cancer. *Value In Health: The Journal Of The International Society For Pharmacoeconomics And Outcomes Research* 2006 Mar;9(2):123-31.
- (21) Hawkins N, Scott DA, Woods B. How far do you go? Efficient searching for indirect evidence. *Medical Decision Making* 2009;29(3):273-81.
- (22) Ioannidis JP. Indirect comparisons: the mesh and mess of clinical trials. *Lancet* 2006 Oct 28;1470-1472.
- (23) Jansen JP, Crawford B, Bergman G, Stam W. Bayesian meta-analysis of multiple treatment comparisons: an introduction to mixed treatment comparisons. *Value In Health: The Journal Of The International Society For Pharmacoeconomics And Outcomes Research* 2008 Sep;11(5):956-64.

- (24) Juni P, Stettler C, Shang A, Reichenbach S, Allemann S, Windecker S. Exploring and summarising networks of trials comparing multiple interventions. Frequentist and Bayesian approaches to network meta-analysis [abstract]. XIV Cochrane Colloquium; 2006 October 23-26; Dublin, Ireland 2006;129.
- (25) Le H, Schmidt FL. Correcting for indirect range restriction in meta-analysis: testing a new meta-analytic procedure. *Psychol Methods* 2006 Dec;11(4):416-38.
- (26) Lu G, Ades AE. Combination of direct and indirect evidence in mixed treatment comparisons. *Statistics In Medicine* 2004 Oct 30;23(20):3105-24.
- (27) Lu G, Ades AE, Sutton AJ, Cooper NJ, Briggs AH, Caldwell DM. Meta-analysis of mixed treatment comparisons at multiple follow-up times. *Statistics In Medicine* 2007 Sep 10;26(20):3681-99.
- (28) Lu G, Ades A. Modeling between-trial variance structure in mixed treatment comparisons. *Biostatistics* 2009 Oct;10(4):792-805.
- (29) Lumley T. Network meta-analysis for indirect treatment comparisons. *Statistics In Medicine* 2002 Aug 30;21(16):2313-24.
- (30) O'Regan C, Ghement I, Eyawo O, Guyatt GH, Mills EJ. Incorporating multiple interventions in meta-analysis: an evaluation of the mixed treatment comparison with the adjusted indirect comparison. *Trials* 2009;10:86.
- (31) Salanti G, Higgins JPT, Ades AE, Ioannidis JPA. Evaluation of networks of randomized trials. *Statistical Methods In Medical Research* 2008 Jun;17(3):279-301.
- (32) Salonen R. Drug comparisons: why are they so difficult? *Cephalalgia: An International Journal Of Headache* 2000;20 Suppl 2:25-32.
- (33) Schöttker B, Lühmann D, Boukhemair D, Raspe H. Indirekte Vergleiche von Therapieverfahren. (German). *GMS Health Technology Assessment* 2009 Jan;5:1-13.
- (34) Shrier I, Steele R, Platt R. A novel approach to mixed-treatment meta-analyses [abstract]. XIV Cochrane Colloquium; 2006 October 23-26; Dublin, Ireland 2006;55.
- (35) Song F, Glenny AM, Altman DG. Indirect comparison in evaluating relative efficacy illustrated by antimicrobial prophylaxis in colorectal surgery. *Controlled Clinical Trials* 2000 Oct;21(5):488-97.
- (36) Song F, Altman DG, Glenny AM, Deeks JJ. Validity of indirect comparison for estimating efficacy of competing interventions: empirical evidence from published meta-analyses. *British Medical Journal* 2003;326(7387):472.
- (37) Song F, Harvey I, Lilford R. Discrepancy between direct comparison and adjusted indirect comparison of new versus conventional pharmaceutical interventions [abstract]. XIV Cochrane Colloquium; 2006 October 23-26; Dublin, Ireland 2006;167.
- (38) Song F, Harvey I, Lilford R. Adjusted indirect comparison may be less biased than direct comparison for evaluating new pharmaceutical interventions. *Journal Of Clinical Epidemiology* 2008 May;61(5):455-63.
- (39) Song F, Loke YK, Walsh T, Glenny AM, Eastwood AJ, Altman DG. Methodological problems in the use of indirect comparisons for evaluating healthcare interventions: survey of published systematic reviews. *BMJ* 2009;338:b1147.
- (40) Song F, Loke Y, Walsh T, Glenny A-M, Eastwood A, Deeks J, et al. Empirical evidence on the validity of adjusted indirect comparison: an updated review [abstract]. 17th Cochrane Colloquium; 2009 Oct 11-14; Singapore 2009;69.
- (41) Song FJ, Yoon YK WT, Glenny AM, Eastwood AJ, Altman DG. Indirect comparisons for evaluation healthcare interventions: review of published systematic reviews and discussion of methodological problems. Oral presentation at the 16th Cochrane Colloquium: Evidence in the era of globalisation; 2008 Oct 3-7; Freiburg, Germany [abstract]. *Zeitschrift fur Evidenz, Fortbildung und Qualitat im Gesundheitswesen* 2008;102(Suppl VI):12.
- (42) Sutton A, Ades AE, Cooper N, Abrams K. Use of indirect and mixed treatment comparisons for technology assessment. *Pharmacoeconomics* 2008;26(9):753-67.
- (43) Sutton AJ, Cooper NJ, Jones DR. Formalising the use of evidence synthesis to designing future research coherently and efficiently: a framework proposal. Poster presentation at the 16th Cochrane Colloquium: Evidence in the era of globalisation; 2008 Oct 3-7; Freiburg, Germany [abstract]. *Zeitschrift fur Evidenz, Fortbildung und Qualitat im Gesundheitswesen* 2008;102:45.
- (44) Sutton AJ, Cooper NJ, Jones DR. Evidence synthesis as the key to more coherent and efficient research. *BMC Medical Research Methodology* 2009;9:29.
- (45) Thorlund K, Steele R, Platt R, Carlisle J, Shrier I. Combining multiple imputation and Bayesian model selection to reduce inconsistency in multiple treatment meta-analysis. Poster presentation at the 16th Cochrane Colloquium: Evidence in the era of globalisation; 2008 Oct 3-7; Freiburg, Germany [abstract]. *Zeitschrift fur Evidenz, Fortbildung und Qualitat im Gesundheitswesen* 2008;102(Suppl VI):93.
- (46) Tudur SC, Williamson P, Marson A. Totality of evidence: using indirect evidence to bridge the gaps [abstract]. 12th Cochrane Colloquium: Bridging the Gaps; 2004 Oct 2-6; Ottawa, Ontario, Canada 2004;78.
- (47) Wiebe N, Barrowman N, Platt R, Klassen T. Methods for variance imputation in meta-analysis: a systematic review [abstract]. XI Cochrane Colloquium: Evidence, Health Care and Culture; 2003 Oct 26-31; Barcelona, Spain 2003;51.

Application of direct and indirect methods:

- (1) Zonisamide: new drug. No advantage in refractory partial epilepsy. *Prescrire International* 2007 Jun;16(89):95-7.
- (2) Department of Error. *Lancet* 369[9572], 1518. 5-5-2007.
- (3) Department of Error. *Lancet* 374[9687], 378. 8-8-2009.

- (4) Correction: Research. CMAJ: Canadian Medical Association Journal 182[8], 806. 18-5-2010. Canadian Medical Association.
- (5) Abdullah AK, Khan S. Relative oral corticosteroid-sparing effect of 7 inhaled corticosteroids in chronic asthma: a meta-analysis [corrected] [published erratum appears in ANN ALLERGY ASTHMA IMMUNOL 2008 Nov;101(5):557]. *Annals of Allergy, Asthma & Immunology* 2008 Jul;101(1):74-81.
- (6) Abdullah AK, Khan S. Relative oral corticosteroid-sparing effect of 7 inhaled corticosteroids in chronic asthma: a meta-analysis. *Ann Allergy Asthma Immunol* 2008 Jul;101(1):74-81.
- (7) Abou-Setta AM. Firm embryo transfer catheters for assisted reproduction: a systematic review and meta-analysis using direct and adjusted indirect comparisons. *Reproductive Biomedicine Online* 2006 Feb;12(2):191-8.
- (8) Ara R, Pandor A, Stevens J, Rees A, Rafia R. Early high-dose lipid-lowering therapy to avoid cardiac events: a systematic review and economic evaluation. *Health Technology Assessment* 2009;13(34):1-118.
- (9) Bagust A, Boland A, Hockenhull J, Fleeman N, Greenhalgh J, Dundar Y, et al. Rituximab for the treatment of rheumatoid arthritis. *Health Technology Assessment* 2009 Feb;13:23-9.
- (10) Baker WL, White CM, Coleman CI. The impact of angiotensin II receptor blocker potency on the clinical outcomes of stroke, acute myocardial infarction, or death. (cover story). *Formulary* 2007 Oct;42(10):581-98.
- (11) Baker WL, Baker EL, Coleman CI. Pharmacologic treatments for chronic obstructive pulmonary disease: a mixed-treatment comparison meta-analysis. *Pharmacotherapy* 2009 Aug;29(8):891-905.
- (12) Ballesteros J. Orphan comparisons and indirect meta-analysis: a case study on antidepressant efficacy in dysthymia comparing tricyclic antidepressants, selective serotonin reuptake inhibitors, and monoamine oxidase inhibitors by using general linear models. *Journal Of Clinical Psychopharmacology* 2005 Apr;25(2):127-31.
- (13) Bandelow B, Seidler-Brandler U, Becker A, Wedekind D, R  ther E. Meta-analysis of randomized controlled comparisons of psychopharmacological and psychological treatments for anxiety disorders. *The World Journal Of Biological Psychiatry: The Official Journal Of The World Federation Of Societies Of Biological Psychiatry* 2007;8(3):175-87.
- (14) Bansback N, Sizto S, Sun H, Feldman S, Willian MK, Anis A. Efficacy of systemic treatments for moderate to severe plaque psoriasis: systematic review and meta-analysis. *Dermatology* 2009;219(3):209-18.
- (15) Batterham MJ. Investigating heterogeneity in studies of resting energy expenditure in persons with HIV/AIDS: a meta-analysis. *American Journal of Clinical Nutrition* 2005 Mar;81(3):702-13.
- (16) Baumgartner RW. Network meta-analysis of antiplatelet treatments for secondary stroke prevention. *European Heart Journal* 2008 May;29(9):1082-3.
- (17) Benish SG, Imel ZE, Wampold BE. The relative efficacy of bona fide psychotherapies for treating post-traumatic stress disorder: a meta-analysis of direct comparisons. *Clinical Psychology Review* 2008 Jun;28(5):746-58.
- (18) Berner MM, Kriston L, Harms A. Efficacy of PDE-5-inhibitors for erectile dysfunction. A comparative meta-analysis of fixed-dose regimen randomized controlled trials administering the International Index of Erectile Function in broad-spectrum populations. *International Journal Of Impotence Research* 2006 May;18(3):229-35.
- (19) Berry C, Norrie J, McMurray JJV. Ximelagatran compared with warfarin for the prevention of systemic embolism and stroke. An imputed placebo analysis. *Cardiovascular Drugs And Therapy / Sponsored By The International Society Of Cardiovascular Pharmacotherapy* 2005 Mar;19(2):149-51.
- (20) Bhandari M, Tornetta P, III, Hanson B, Swiontkowski MF. Optimal internal fixation for femoral neck fractures: multiple screws or sliding hip screws? *J Orthop Trauma* 2009 Jul;23(6):403-7.
- (21) Biondi-Zoccai G, Lotrionte M, Moretti C, Agostoni P, Sillano D, Laudito A, et al. Percutaneous coronary intervention with everolimus-eluting stents (Xience V): systematic review and direct-indirect comparison meta-analyses with paclitaxel-eluting stents (Taxus) and sirolimus-eluting stents (Cypher). *Minerva Cardioangiologica* 2008 Feb;56(1):55-65.
- (22) Biondi-Zoccai GG, Agostoni P, Abbate A, Testa L, Burzotta F, Lotrionte M, et al. Adjusted indirect comparison of intracoronary drug-eluting stents: evidence from a metaanalysis of randomized bare-metal-stent-controlled trials. *Int J Cardiol* 2005 Apr 8;100(1):119-23.
- (23) Biondi-Zoccai GGL, Lotrionte M, Abbate A, Valgimigli M, Testa L, Burzotta F, et al. Direct and indirect comparison meta-analysis demonstrates the superiority of sirolimus- versus paclitaxel-eluting stents across 5854 patients. *International Journal of Cardiology* 2007 Jan 2;114(1):104-5.
- (24) Bolon MK, Wright SB, Gold HS, Carmeli Y. The magnitude of the association between fluoroquinolone use and quinolone-resistant *Escherichia coli* and *Klebsiella pneumoniae* may be lower than previously reported. *Antimicrob Agents Chemother* 2004 Jun;48(6):1934-40.
- (25) Bond M, Hoyle M, Moxham T, Napier M, Anderson R. Sunitinib for the treatment of gastrointestinal stromal tumours: a critique of the submission from Pfizer. *Health Technology Assessment* 2009 Feb;13:69-74.
- (26) Boonen S, Lips P, Bouillon R, Bischoff-Ferrari HA, Vanderschueren D, Haentjens P. Need for additional calcium to reduce the risk of hip fracture with vitamin d supplementation: evidence from a comparative meta-analysis of randomized controlled trials. *J Clin Endocrinol Metab* 2007 Apr;92(4):1415-23.
- (27) Bravo VY, Dunn G, Asseburg C, Beynon S, Woolacott N, Soares-Weiser K, et al. A simultaneous comparison of multiple pharmacological treatments for bipolar disorder: an application of Bayesian statistical methods [abstract]. XIV Cochrane Colloquium; 2006 October 23-26; Dublin, Ireland 2006;159.
- (28) Brophy JM, Joseph L. Medical decision making with incomplete evidence--choosing a platelet glycoprotein IIb/IIIa receptor inhibitor for percutaneous coronary interventions. *Medical Decision Making: An International Journal Of The Society For Medical Decision Making* 2005 Mar;25(2):222-8.

- (29) Brown TJ, Hooper L, Elliott RA, Payne K, Webb R, Roberts C, et al. A comparison of the cost-effectiveness of five strategies for the prevention of non-steroidal anti-inflammatory drug-induced gastrointestinal toxicity: a systematic review with economic modelling. *Health Technol Assess* 2006 Oct;10(38):iii-xiii, 1.
- (30) Caldwell D, Ades T, Higgins J. Mixed treatment comparison analysis of seven treatments for acute myocardial infarction [abstract]. XIII Cochrane Colloquium; 2005 Oct 22-26; Melbourne, Australia 2005;58.
- (31) Carre-Pierrat Mt, Baillie D, Johnsen R, Hyde R, Hart A, Granger L, et al. Characterization of the *Caenorhabditis elegans* G protein-coupled serotonin receptors. *Invertebrate Neuroscience*: IN 2006 Dec;6(4):189-205.
- (32) Casetta I, Juliano G, Filippini G. Azathioprine for multiple sclerosis. *Cochrane Database of Systematic Reviews* 2007 Dec;(4).
- (33) Centre for Reviews and Dissemination. Atypical antipsychotics in the treatment of schizophrenia: systematic overview and meta-regression analysis (Structured abstract). Geddes J, Freemantle N, Harrison P, Bebbington P, editors. *BMJ* 321, 1371-1376. 2000.
- (34) Centre for Reviews and Dissemination. Antiplatelet therapy and other interventions after revascularisation procedures in patients with peripheral arterial disease: a meta-analysis (Structured abstract). Girolami B, Bernardi E, Prins MH, Cate JW, Prandoni P, Simioni P et al., editors. *European Journal of Vascular and Endovascular Surgery* 19[4], 370-380. 2000.
- (35) Centre for Reviews and Dissemination. Helicobacter pylori eradication: proton pump inhibitor versus ranitidine bismuth citrate plus two antibiotics for 1 week. A meta-analysis of efficacy (Structured abstract). Gisbert JP, Gonzalez L, Calvet X, Roque M, Gabriel R, Pajares JM, editors. *Alimentary Pharmacology and Therapeutics* 14[9], 1141-1150. 2000.
- (36) Centre for Reviews and Dissemination. Meta-analysis of the effect of latanoprost and brimonidine on intraocular pressure in the treatment of glaucoma (Structured abstract). Einarson TR, Kulin NA, Tingey D, Iskedjian M, editors. *Clinical Therapeutics* 22[12], 1502-1515. 2000.
- (37) Centre for Reviews and Dissemination. Peripheral arterial disease: gadolinium-enhanced MR angiography versus color-guided duplex US. A meta-analysis (Structured abstract). Visser K, Hunink MG, editors. *Radiology* 216[1], 67-77. 2000.
- (38) Centre for Reviews and Dissemination. Combination regimens of topical calcipotriene in chronic plaque psoriasis: systematic review of efficacy and tolerability (Structured abstract). Ashcroft DM, Li Wan Po A, Williams HC, Griffiths CE, editors. *Archives of Dermatology* 136[12], 1536-1543. 2000.
- (39) Centre for Reviews and Dissemination. Do the low molecular weight heparins improve efficacy and safety of the treatment of deep venous thrombosis: a meta-analysis (Structured abstract). Rocha E, Martinez-Gonzalez MA, Montes R, Panizo C, editors. *Haematologica* 85[9], 935-942. 2000.
- (40) Centre for Reviews and Dissemination. Effectiveness of interventions to improve follow-up after abnormal cervical cancer screening (Structured abstract). Yabroff KR, Kerner JF, Mandelblatt JS, editors. *Preventive Medicine* 31[4], 429-439. 2000.
- (41) Centre for Reviews and Dissemination. Risk of cardiovascular events associated with selective COX-2 inhibitors (Structured abstract). Mukherjee D, Nissen SE, Topol EJ, editors. *JAMA* 286[8], 954-959. 2001.
- (42) Centre for Reviews and Dissemination. Systematic review of long term anticoagulation or antiplatelet treatment in patients with non-rheumatic atrial fibrillation (Structured abstract). Taylor FC, Cohen H, Ebrahim S, editors. *BMJ* 322. 2001.
- (43) Centre for Reviews and Dissemination. Treatment of open fractures of the shaft of the tibia: a systematic overview and meta-analysis (Structured abstract). Bhandari M, Guyatt GH, Swiontkowski MF, Schemitsch EH, editors. *Journal of Bone and Joint Surgery*. British volume 83GÇĘB[1], 62-68. 2001.
- (44) Centre for Reviews and Dissemination. A systematic review of the peripheral analgesic effects of intraarticular morphine (Structured abstract). Gupta A, Bodin L, Holmstrom B, Berggren L, editors. *Anesthesia And Analgesia* 93[3], 761-770. 2001.
- (45) Centre for Reviews and Dissemination. An effect-size analysis of the relative efficacy and tolerability of serotonin selective reuptake inhibitors for panic disorder (Structured abstract). Otto MW, Tuby KS, Gould RA, McLean RY, Pollack MH, editors. *American Journal of Psychiatry* 158[12], 1989-1992. 2001.
- (46) Centre for Reviews and Dissemination. Infarct artery reocclusion after primary angioplasty, stent placement, and thrombolytic therapy for acute myocardial infarction (Structured abstract). Wilson SH, Bell MR, Rihal CS, Bailey KR, Holmes DR, Berger PB, editors. *American Heart Journal* 141[5], 704-710. 2001.
- (47) Centre for Reviews and Dissemination. Labor induction with 25 microg versus 50 microg intravaginal misoprostol: a systematic review (Structured abstract). Sanchez Ramos L, Kaunitz AM, Delke I, editors. *Obstetrics And Gynecology* 99[1], 145-151. 2002.
- (48) Centre for Reviews and Dissemination. Health outcomes associated with various antihypertensive therapies used as first-line agents: a network meta-analysis (Structured abstract). Psaty BM, Lumley T, Furberg CD, Schellenbaum G, Pahor M, Alderman MH et al., editors. *JAMA* 289[19], 2534-2544. 2003.
- (49) Centre for Reviews and Dissemination. Meta-analysis of trials of interventions to improve medication adherence (Structured abstract). Peterson AM, Takiya L, Finley R, editors. *American Journal of Health System Pharmacy* 60[7], 657-665. 2003.
- (50) Centre for Reviews and Dissemination. The effect of treatment on radiological progression in rheumatoid arthritis: a systematic review of randomized placebo-controlled trials (Structured abstract). Jones G, Halbert J, Crotty M, Shanahan EM, Batterham M, Ahern M, editors. *Rheumatology* 42[1], 6-13. 2003.

- (51) Centre for Reviews and Dissemination. Effects of different blood-pressure-lowering regimens on major cardiovascular events: results of prospectively-designed overviews of randomised trials (Structured abstract). Turnbull F, Neal B, Algert C, Chalmers J, Woodward M, MacMahon S, editors. *Lancet* 362, 1527-1535. 2003.
- (52) Centre for Reviews and Dissemination. Indirect comparison meta-analysis of aspirin therapy after coronary surgery (Structured abstract). Lim E, Ali Z, Ali A, Routledge T, Edmonds L, Altman DG et al., editors. *BMJ* 327, 1309-1311. 2003.
- (53) Centre for Reviews and Dissemination. Characteristics of effective school-based substance abuse prevention (Structured abstract). Gottfredson DC, Wilson DB, editors. *Prevention Science* 4[1], 27-38. 2003.
- (54) Centre for Reviews and Dissemination. Clinical trial response and dropout rates with olanzapine versus risperidone (Structured abstract). Santarlaschi B, Messori A, editors. *Annals of Pharmacotherapy* 37[4], 556-563. 2003.
- (55) Centre for Reviews and Dissemination. Effectiveness of proton pump inhibitors in nonerosive reflux disease (Structured abstract). Dean BB, Gano AD, Knight K, Ofman JJ, Fass R, editors. *Clinical Gastroenterology and Hepatology* 2[8], 656-664. 2004.
- (56) Centre for Reviews and Dissemination. Antibiotics for reduction of posttonsillectomy morbidity: a meta-analysis (Structured abstract). Burkart CM, Steward DL, editors. *Laryngoscope* 115[6], 997-1002. 2005.
- (57) Centre for Reviews and Dissemination. Drug-eluting stents versus bare metal stents in percutaneous coronary interventions (a meta-analysis) (Structured abstract). Indolfi C, Pavia M, Angelillo IF, editors. *American Journal of Cardiology* 95[10], 1146-1152. 2005.
- (58) Centre for Reviews and Dissemination. Duloxetine and venlafaxine-XR in the treatment of major depressive disorder: a meta-analysis of randomized clinical trials (Structured abstract). Vis PM, Baardewijk M, Einarson TR, editors. *Annals of Pharmacotherapy* 39[11], 1798-1807. 2005.
- (59) Centre for Reviews and Dissemination. A comparison of olanzapine versus risperidone for the treatment of schizophrenia: a meta-analysis of randomised clinical trials (Structured abstract). Mudge MA, Davey PJ, Coleman KA, Montgomery W, Croker VS, Mullen K et al., editors. *International Journal of Psychiatry in Clinical Practice* 9[1], 3-15. 2005.
- (60) Centre for Reviews and Dissemination. Adjusted indirect comparison of intracoronary drug-eluting stents: evidence from a metaanalysis of randomized bare-metal-stent-controlled trials (Structured abstract). Biondi-Zoccai GG, Agostoni P, Abbate A, Testa L, Burzotta F, Lotrionte M et al., editors. *International Journal of Cardiology* 100[1], 119-123. 2005.
- (61) Centre for Reviews and Dissemination. Aerobic walking or strengthening exercise for osteoarthritis of the knee: a systematic review (Structured abstract). Roddy E, Zhang W, Doherty M, editors. *Annals Of The Rheumatic Diseases* 64[4], 544-548. 2005.
- (62) Centre for Reviews and Dissemination. Treatments for later-life depressive conditions: a meta-analytic comparison of pharmacotherapy and psychotherapy (Structured abstract). Pinquart M, Duberstein PR, Lyness JM, editors. *American Journal of Psychiatry* 163[9], 1493-1501. 2006.
- (63) Centre for Reviews and Dissemination. The comparative efficacy and safety of biologics for the treatment of rheumatoid arthritis: a systematic review and metaanalysis (Structured abstract). Gartlehner G, Hansen RA, Jonas BL, Thieda P, Lohr KN, editors. *Journal of Rheumatology* 33[12], 2398-2408. 2006.
- (64) Centre for Reviews and Dissemination. Survival benefits with diverse chemotherapy regimens for ovarian cancer: meta-analysis of multiple treatments (Structured abstract). Kyrgiou M, Salanti G, Pavlidis N, Paraskevaidis E, Ioannidis JP, editors. *Journal of the National Cancer Institute* 98[22], 1655-1663. 2006.
- (65) Centre for Reviews and Dissemination. Differential effectiveness of behavioral parent-training and cognitive-behavioral therapy for antisocial youth: a meta-analysis (Structured abstract). McCart MR, Priester PE, Davies WH, Azen R, editors. *Journal of Abnormal Child Psychology* 34[4], 527-543. 2006.
- (66) Centre for Reviews and Dissemination. Drug eluting stents: an updated meta-analysis of randomised controlled trials (Structured abstract). Roiron C, Sanchez P, Bouzamondo A, Lechat P, Montalescot G, editors. *Heart* 92[5], 641-649. 2006.
- (67) Centre for Reviews and Dissemination. Echinacea in the prevention of induced rhinovirus colds: a meta-analysis (Structured abstract). Schoop R, Klein P, Suter A, Johnston SL, editors. *Clinical Therapeutics* 28[2], 174-183. 2006.
- (68) Centre for Reviews and Dissemination. Efficacy and safety of balloon kyphoplasty in the treatment of vertebral compression fractures: a systematic review (Structured abstract). Bouza C, Lopez T, Magro A, Navalpotro L, Amate JM, editors. *European Spine Journal* 15[7], 1050-1067. 2006.
- (69) Centre for Reviews and Dissemination. Strategies for discontinuing long-term benzodiazepine use: meta-analysis (Structured abstract). Oude Voshaar RC, Couvee JE, Balkom AJ, Mulder PG, Zitman FG, editors. *British Journal of Psychiatry* 189, 213-220. 2006.
- (70) Centre for Reviews and Dissemination. Anti-TNF antibody therapy in rheumatoid arthritis and the risk of serious infections and malignancies: systematic review and meta-analysis of rare harmful effects in randomized controlled trials (Structured abstract). Bongartz T, Sutton AJ, Sweeting MJ, Buchan I, Matteson EL, Montori V, editors. *JAMA* 295[19], 2275-2285. 2006.
- (71) Centre for Reviews and Dissemination. Assessing the diagnostic test accuracy of natriuretic peptides and ECG in the diagnosis of left ventricular systolic dysfunction: a systematic review and meta-analysis (Structured abstract). Davenport C, Cheng EY, Kwok YT, Lai AH, Wakabayashi T, Hyde C et al., editors. *British Journal of General Practice* 56, 48-56. 2006.
- (72) Centre for Reviews and Dissemination. Are statins created equal: evidence from randomized trials of pravastatin, simvastatin, and atorvastatin for cardiovascular disease prevention (Structured abstract). Zhou Z, Rahme E, Pilote L, editors. *American Heart Journal* 151[2], 273-281. 2006.

- (73) Centre for Reviews and Dissemination. Diagnostic precision of nanoparticle-enhanced MRI for lymph-node metastases: a meta-analysis (Structured abstract). Will O, Purkayastha S, Chan C, Athanasiou T, Darzi AW, Gedroyc W et al., editors. *Lancet Oncology* 7[1], 52-60. 2006.
- (74) Centre for Reviews and Dissemination. Meta-analysis of comparative diagnostic performance of magnetic resonance imaging and multislice computed tomography for noninvasive coronary angiography (Structured abstract). Schuijff JD, Bax JJ, Shaw LJ, Roos A, Lamb HJ, Wall EE et al., editors. *American Heart Journal* 151[2], 404-411. 2006.
- (75) Centre for Reviews and Dissemination. Etanercept and efalizumab for the treatment of psoriasis: a systematic review (Structured abstract). 2006.
- (76) Centre for Reviews and Dissemination. Efficacy of drug eluting stents in patients with and without diabetes mellitus: indirect comparison of controlled trials (Structured abstract). Stettler C, Allemann S, Egger M, Windecker S, Meier B, Diem P, editors. *Heart* 92[5], 650-657. 2006.
- (77) Centre for Reviews and Dissemination. Risk of corneal inflammatory events with silicone hydrogel and low Dk hydrogel extended contact lens wear: a meta-analysis (Structured abstract). Szczotka-Flynn L, Diaz M, editors. *Optometry and Vision Science* 84[4], 247-256. 2007.
Ref Type: Generic
- (78) Centre for Reviews and Dissemination. Does the use of preoperative aspirin increase the risk of bleeding in patients undergoing coronary artery bypass grafting surgery: systematic review and meta-analysis (Structured abstract). Alghamdi AA, Moussa F, Fremes SE, editors. *Journal of Cardiac Surgery* 22[3], 247-256. 2007.
- (79) Centre for Reviews and Dissemination. Pharmacological and lifestyle interventions to prevent or delay type 2 diabetes in people with impaired glucose tolerance: systematic review and meta-analysis (Structured abstract). Gillies CL, Abrams KR, Lambert PC, Cooper NJ, Sutton AJ, Hsu RT et al., editors. *BMJ* 334, 299. 2007.
- (80) Centre for Reviews and Dissemination. The clinical effectiveness and cost-effectiveness of strontium ranelate for the prevention of osteoporotic fragility fractures in postmenopausal women (Structured abstract). Stevenson M, Davis S, Lloyd-Jones M, Beverley C, editors. *Health Technology Assessment* 11[4], 1-134. 2007.
- (81) Centre for Reviews and Dissemination. Use of octreotide for the prevention of pancreatic fistula after elective pancreatic surgery: a systematic review and meta-analysis (Structured abstract). Alghamdi AA, Jawas AM, Hart RS, editors. *Canadian Journal of Surgery* 50[6], 459-466. 2007.
- (82) Centre for Reviews and Dissemination. The number needed to treat for adalimumab, etanercept, and infliximab based on ACR50 response in three randomized controlled trials on established rheumatoid arthritis: a systematic literature review (Structured abstract). Kristensen LE, Christensen R, Bliddal H, Geborek P, Danneskiold-Samsøe B, Saxne T, editors. *Scandinavian Journal of Rheumatology* 36[6], 411-417. 2007.
- (83) Centre for Reviews and Dissemination. The efficacy of behavioral interventions in reducing HIV risk sex behaviors and incident sexually transmitted disease in black and Hispanic sexually transmitted disease clinic patients in the United States: a meta-analytic review (Structured abstract). Crepez N, Horn AK, Rama SM, Griffin T, Deluca JB, Mullins MM et al., editors. *Sexually Transmitted Diseases* 34[6], 319-332. 2007.
- (84) Centre for Reviews and Dissemination. Deliberate hypotension in orthopedic surgery reduces blood loss and transfusion requirements: a meta-analysis of randomized controlled trials (Structured abstract). Paul JE, Ling E, Lalonde C, Thabane L, editors. *Canadian Journal of Anaesthesia* 54[10], 799-810. 2007.
- (85) Centre for Reviews and Dissemination. Antifungal prophylaxis in cancer patients after chemotherapy or hematopoietic stem-cell transplantation: systematic review and meta-analysis (Structured abstract). Robenshtok E, Gafter-Gvili A, Goldberg E, Weinberger M, Yeshurun M, Leibovici L et al., editors. *Journal of Clinical Oncology* 25[34], 5471-5489. 2007.
- (86) Centre for Reviews and Dissemination. Meta-analysis of mixed treatment comparisons at multiple follow-up times (Brief record). *Statistics In Medicine* 2007;26(20):3681-99.
- (87) Centre for Reviews and Dissemination. Thiazolidinediones and the risk of edema: a meta-analysis (Structured abstract). Berlie HD, Kalus JS, Jaber LA, editors. *Diabetes Research and Clinical Practice* 76[2], 279-289. 2007.
- (88) Centre for Reviews and Dissemination. Cost-effectiveness of pegaptanib compared to photodynamic therapy with verteporfin and to standard care in the treatment of subfoveal wet age-related macular degeneration in Canada (Structured abstract). *Clinical Therapeutics* 2007;29(9):2096-106.
- (89) Centre for Reviews and Dissemination. A cost-effectiveness analysis of angiotensin-converting enzyme inhibitors and angiotensin receptor blockers in diabetic nephropathy (Structured abstract). *Journal of Clinical Hypertension* 2007;9(10):751-9.
- (90) Centre for Reviews and Dissemination. Hylan versus hyaluronic acid for osteoarthritis of the knee: a systematic review and meta-analysis (Structured abstract). Reichenbach S, Blank S, Rutjes AW, Shang A, King EA, Dieppe PA et al., editors. *Arthritis And Rheumatism* 57[8], 1410-1418. 2007.
- (91) Centre for Reviews and Dissemination. Behavioral activation treatments of depression: a meta-analysis (Structured abstract). Cuijpers P, Straten A, Warmerdam L, editors. *Clinical Psychology Review* 27[3], 318-326. 2007.
- (92) Centre for Reviews and Dissemination. Chemotherapy compared with biochemotherapy for the treatment of metastatic melanoma: a meta-analysis of 18 trials involving 2,621 patients (Structured abstract). Ives NJ, Stowe RL, Lorigan P, Wheatley K, editors. *Journal of Clinical Oncology* 25[34], 5426-5434. 2007.
- (93) Centre for Reviews and Dissemination. Clinical impact of adjuvant chemotherapy in glioblastoma multiforme: a meta-analysis (Structured abstract). Spiegel BM, Esrailian E, Laine L, Chamberlain MC, editors. *CNS Drugs* 21[9], 775-787. 2007.
- (94) Centre for Reviews and Dissemination. A meta-analysis of topical prostaglandin analogues intra-ocular pressure lowering in glaucoma therapy (Structured abstract). Denis P, Lafuma A, Khoshnood B, Mimaud V, Berdeaux G, editors. *Current Medical Research And Opinion* 23[3], 601-608. 2007.

- (95) Centre for Reviews and Dissemination. Twice vs three times daily heparin dosing for thromboembolism prophylaxis in the general medical population: a meta-analysis (Structured abstract). King CS, Holley AB, Jackson JL, Shorr AF, Moores LK, editors. *Chest* 131[2], 507-516. 2007.
- (96) Centre for Reviews and Dissemination. Adalimumab, etanercept and infliximab for the treatment of ankylosing spondylitis: a systematic review and economic evaluation (Structured abstract). McLeod C, Bagust A, Boland A, Dagenais P, Dickson R, Dundar Y et al., editors. *Health Technology Assessment* 11[28], 1-158. 2007.
- (97) Centre for Reviews and Dissemination. Drug eluting and bare metal stents in people with and without diabetes: collaborative network meta-analysis (Structured abstract). Stettler C, Allemann S, Wandel S, Kastrati A, Morice MC, Schömig A et al., editors. *BMJ* . 2008.
- (98) Centre for Reviews and Dissemination. How much does pharmacologic prophylaxis reduce postoperative vomiting in children? Calculation of prophylaxis effectiveness and expected incidence of vomiting under treatment using Bayesian meta-analysis (Structured abstract). Engelman E, Salengros JC, Barvais L, editors. *Anesthesiology* 109[6], 1023-1035. 2008.
- (99) Centre for Reviews and Dissemination. Relative oral corticosteroid-sparing effect of 7 inhaled corticosteroids in chronic asthma: a meta-analysis (Structured abstract). Abdullah AK, Khan S, editors. *Annals of Allergy, Asthma and Immunology* 101[1], 74-81. 2008.
- (100) Centre for Reviews and Dissemination. Long-term antidepressant treatment in bipolar disorder: meta-analyses of benefits and risks (Structured abstract). Ghaemi SN, Wingo AP, Filkowski MA, Baldessarini RJ, editors. *Acta Psychiatrica Scandinavica* 118[5], 347-356. 2008.
- (101) Centre for Reviews and Dissemination. A meta-analysis of parent-involved treatment for child sexual abuse (Structured abstract). Corcoran J, Pillai V, editors. *Research on Social Work Practice* 18[5], 453-464. 2008.
- (102) Centre for Reviews and Dissemination. Cost utility analysis of early adjuvant letrozole or anastrozole versus tamoxifen in postmenopausal women with early invasive breast cancer: the UK perspective (Structured abstract). *European Journal of Health Economics* 2008;9:171-83.
- (103) Centre for Reviews and Dissemination. Computer aids and human second reading as interventions in screening mammography: two systematic reviews to compare effects on cancer detection and recall rate (Structured abstract). Taylor P, Potts HW, editors. *European Journal of Cancer* 44[6], 798-807. 2008.
- (104) Centre for Reviews and Dissemination. Antihypertensive medication and their impact on cancer incidence: a mixed treatment comparison meta-analysis of randomized controlled trials (Structured abstract). Coleman CI, Baker WL, Kluger J, White CM, editors. *Journal of Hypertension* 26[4], 622-629. 2008.
- (105) Centre for Reviews and Dissemination. Statins and cancer: a systematic review and meta-analysis (Structured abstract). Kuoppala J, Lamminpää A, Pukkala E, editors. *European Journal of Cancer* 44[15], 2122-2132. 2008.
- (106) Centre for Reviews and Dissemination. Repeat thrombolysis or conservative therapy vs. rescue percutaneous coronary intervention for failed thrombolysis: systematic review and meta-analysis (Structured abstract). Testa L, Gaal WJ, Biondi-Zoccai GG, Abbate A, Agostoni P, Bhandi R et al., editors. *QJM: an International Journal of Medicine* 101[5], 387-395. 2008.
- (107) Centre for Reviews and Dissemination. The relative efficacy of bona fide psychotherapies for treating post-traumatic stress disorder: a meta-analysis of direct comparisons (Structured abstract). Benish SG, Imel ZE, Wampold BE, editors. *Clinical Psychology Review* 28[5], 746-758. 2008.
- (108) Centre for Reviews and Dissemination. Antifungal treatment for invasive *Candida* infections: a mixed treatment comparison meta-analysis (Provisional abstract). Mills EJ, Perri D, Cooper C, Nachege JB, Wu P, Tleyeh I et al., editors. *Annals Of Clinical Microbiology And Antimicrobials* 8:23. 2009.
- (109) Centre for Reviews and Dissemination. Economic evaluation of systemic therapies for moderate to severe psoriasis (Structured abstract). *British Journal of Dermatology* 2009;160(6):1264-72.
- (110) Centre for Reviews and Dissemination. No study left behind: a network meta-analysis in non-small-cell lung cancer demonstrating the importance of considering all relevant data (Provisional abstract). Hawkins N, Scott DA, Woods BS, Thatcher N, editors. *Value in Health* 12[6], 996-1003. 2009.
- (111) Centre for Reviews and Dissemination. Inhaled drugs to reduce exacerbations in patients with chronic obstructive pulmonary disease: a network meta-analysis (Provisional abstract). Puhan MA, Bachmann LM, Kleijnen J, ter Riet G, Kessels AG, editors. *BMC Medicine* 7[2]. 2009.
- (112) Centre for Reviews and Dissemination. Metastatic renal cell cancer treatments: an indirect comparison meta-analysis (Structured abstract). Mills EJ, Rachlis B, O'Regan C, Thabane L, Perri D, editors. *BMC Cancer* 9:34. 2009.
- (113) Centre for Reviews and Dissemination. Treatment of fibromyalgia syndrome with antidepressants: a meta-analysis (Structured abstract). Hauser W, Bernardy K, Uceyler N, Sommer C, editors. *JAMA* 301[2], 198-209. 2009.
- (114) Centre for Reviews and Dissemination. Percutaneous coronary interventions for non-acute coronary artery disease: a quantitative 20-year synopsis and a network meta-analysis (Structured abstract). Trikalinos TA, Alsheikh-Ali AA, Tatsioni A, Nallamothu BK, Kent DM, editors. *Lancet* 373, 911-918. 2009.
- (115) Centre for Reviews and Dissemination. The effectiveness of intravenous 5-fluorouracil-containing chemotherapy after curative resection for gastric carcinoma: a systematic review of published randomized controlled trials (Structured abstract). Hu JK, Li CM, Chen XZ, Chen ZX, Zhou ZG, Zhang B et al., editors. *Journal of Chemotherapy* 19[4], 359-375. 2010.
- (116) Chilcott J, Lloyd JM, Wilkinson A. Docetaxel for the adjuvant treatment of early node-positive breast cancer: a single technology appraisal. *Health Technol Assess* 2009 Jun;13 Suppl 1:7-13.

- (117) Chlapoutakis K, Theocharopoulos N, Yarmenitis S, Damilakis J. Performance of computed tomographic urography in diagnosis of upper urinary tract urothelial carcinoma, in patients presenting with hematuria: Systematic review and meta-analysis. *European Journal Of Radiology* 2010 Feb;73(2):334-8.
- (118) Chou R, Fu R, Hoyt Huffman L, Korthuis PT. Initial highly-active antiretroviral therapy with a protease inhibitor versus a non-nucleoside reverse transcriptase inhibitor: discrepancies between direct and indirect meta-analyses. *Lancet* 2006 Oct 28;368(9546):1503-15.
- (119) Chou R, Fu R. Validity of indirect comparisons in meta- analysis. *Lancet* 369[9558], 271. 27-1-2007.
- (120) Chung H, Lumley T. Graphical exploration of network meta-analysis data: the use of multidimensional scaling. *Clinical Trials (London, England)* 2008;5(4):301-7.
- (121) Cipriani A, Furukawa TA, Churchill R, Barbui C. Validity of indirect comparisons in meta- analysis. *Lancet* 369[9558], 270-271. 27-1-2007.
- (122) Cipriani A, La Ferla T, Furukawa TA, Signoretti A, Nakagawa A, Churchill R, et al. Sertraline versus other antidepressive agents for depression. *Cochrane Database Of Systematic Reviews (Online)* 2009;(2):CD006117.
- (123) Cipriani A, La Ferla T, Furukawa TA, Signoretti A, Nakagawa A, Churchill R, et al. Sertraline versus other antidepressive agents for depression. *Cochrane Database Of Systematic Reviews (Online)* 2010;4:CD006117.
- (124) Clark W, Jobanputra P, Barton P, Burls A. The clinical and cost-effectiveness of anakinra for the treatment of rheumatoid arthritis in adults: a systematic review and economic analysis. *Health Technology Assessment (Winchester, England)* 2004 May;8(18):iii.
- (125) Coleman CI, Baker WL, Kluger J, White CM. Antihypertensive medication and their impact on cancer incidence: a mixed treatment comparison meta-analysis of randomized controlled trials. *Journal of Hypertension* 2008 Apr;26(4):622-9.
- (126) Collins R, Fenwick E, Trowman R, Perard R, Norman G, Light K, et al. A systematic review and economic model of the clinical effectiveness and cost-effectiveness of docetaxel in combination with prednisone or prednisolone for the treatment of hormone-refractory metastatic prostate cancer. *Health Technology Assessment* 2007;11(2):1-198.
- (127) Connock M, Juarez-Garcia A, Jowett S, Frew E, Liu Z, Taylor RJ, et al. Methadone and buprenorphine for the management of opioid dependence: a systematic review and economic evaluation. *Health Technology Assessment (Winchester, England)* 2007 Mar;11(9):1.
- (128) Coomarasamy A, Knox EM, Gee H, Song F, Khan KS. Effectiveness of nifedipine versus atosiban for tocolysis in preterm labour: a meta-analysis with an indirect comparison of randomised trials. *BJOG: An International Journal Of Obstetrics And Gynaecology* 2003 Dec;110(12):1045-9.
- (129) Cooper NJ, Sutton AJ, Lu G, Khunti K. Mixed comparison of stroke prevention treatments in individuals with nonrheumatic atrial fibrillation. *Arch Intern Med* 2006 Jun 26;166(12):1269-75.
- (130) Cooper NJ, Sutton AJ, Ades AE, Welton NJ. Addressing between-study heterogeneity and inconsistency in mixed treatment comparisons: application to stroke prevention treatments for Atrial Fibrillation patients. Oral presentation at the 16th Cochrane Colloquium: Evidence in the era of globalisation; 2008 Oct 3-7; Freiburg, Germany [abstract]. *Zeitschrift fur Evidenz, Fortbildung und Qualitat im Gesundheitswesen* 2008;102(Suppl VI):21.
- (131) Cooper NJ, Sutton AJ, Morris D, Ades AE, Welton NJ. Addressing between-study heterogeneity and inconsistency in mixed treatment comparisons: Application to stroke prevention treatments in individuals with non-rheumatic atrial fibrillation. *Statistics In Medicine* 2009 Jun 30;28(14):1861-81.
- (132) Cross NB, Webster AC, Masson P, O'Connell PJ, Craig JC. Antihypertensive treatment for kidney transplant recipients. *Cochrane Database of Systematic Reviews* 2009 Sep;(3).
- (133) Cross NB, Webster AC, Masson P, O'Connell PJ, Craig JC. Antihypertensives for kidney transplant recipients: systematic review and meta-analysis of randomized controlled trials. *Transplantation* 2009 Jul 15;88(1):7-18.
- (134) Davies L, Brown TJ, Haynes S, Payne K, Elliott RA, McCollum C. Cost-effectiveness of cell salvage and alternative methods of minimising perioperative allogeneic blood transfusion: a systematic review and economic model. *Health Technology Assessment* 2006;10(44):iii.
- (135) Eckert L, Lancon C. Duloxetine compared with fluoxetine and venlafaxine: use of meta-regression analysis for indirect comparisons. *BMC Psychiatry* 2006;6:30.
- (136) Edwards SJ, Smith CJ. Tolerability of atypical antipsychotics in the treatment of adults with schizophrenia or bipolar disorder: a mixed treatment comparison of randomized controlled trials. *Clinical Therapeutics* 2009 Jun 3;31(Theme Issue):1345-59.
- (137) Edwards SJ, Lind T, Lundell L, DAS R. Systematic review: standard- and double-dose proton pump inhibitors for the healing of severe erosive oesophagitis -- a mixed treatment comparison of randomized controlled trials. *Alimentary Pharmacology & Therapeutics* 2009 Sep 15;30(6):547-56.
- (138) Edwards SJ, Clarke MJ, Wordsworth S, Welton NJ. Carbapenems versus other beta-lactams in the treatment of hospitalised patients with infection: a mixed treatment comparison. *Current Medical Research And Opinion* 2009 Jan;25(1):251-61.
- (139) Einarson TR, Kulin NA, Tingey D, Iskedjian M. Meta-analysis of the effect of latanoprost and brimonidine on intraocular pressure in the treatment of glaucoma. *Clinical Therapeutics* 2000 Dec;22(12):1502-15.
- (140) Eisenberg MJ, Filion KB, Yavin D, Bélisle P, Mottillo S, Joseph L, et al. Pharmacotherapies for smoking cessation: a meta-analysis of randomized controlled trials. *CMAJ: Canadian Medical Association Journal* 2008 Jul 15;179(2):135-44.
- (141) Elliott WJ, Meyer PM. Incident diabetes in clinical trials of antihypertensive drugs: a network meta-analysis. *Lancet* 2007 Jan 20;369(9557):201-7.

- (142) Fakhoury W, Lockhart I, Kotchie RW, Aagren M, LeReun C. Indirect comparison of once daily insulin detemir and glargine in reducing weight gain and hypoglycaemic episodes when administered in addition to conventional oral anti-diabetic therapy in patients with type-2 diabetes. *Pharmacology* 2008;82(2):156-63.
- (143) Golfinopoulos V, Salanti G, Pavlidis N, Ioannidis JPA. Survival and disease-progression benefits with treatment regimens for advanced colorectal cancer: a meta-analysis. *Lancet Oncology* 2007 Oct;8(10):898-911.
- (144) Grandjean EM, Berthet P, Ruffman R, Leuenberger P. Efficacy of oral long-term N-acetylcysteine in chronic bronchopulmonary disease: a meta-analysis of published double-blind, placebo-controlled clinical trials. *Clinical Therapeutics* 2000 Feb;22(2):209-21.
- (145) Hansen RA, Gaynes BN, Gartlehner G, Moore CG, Tiwari R, Lohr KN. Efficacy and tolerability of second-generation antidepressants in social anxiety disorder. *International Clinical Psychopharmacology* 2008 May;23(3):170-9.
- (146) Hansen RA, Gartlehner G, Webb AP, Morgan LC, Moore CG, Jonas DE. Efficacy and safety of donepezil, galantamine, and rivastigmine for the treatment of Alzheimer's disease: a systematic review and meta-analysis. *Clinical Interventions In Aging* 2008;3(2):211-25.
- (147) Hawkins N, Scott DA, Woods BS, Thatcher N. Tim to broaden our horizons: the case for network meta-analysis within relapsed nonsmall cell lung cancer (NSCLC) [abstract]. *Annals of Oncology* 2008;19(Supplement 8):115.
- (148) Hawkins N, Scott DA, Woods BS, Thatcher N. No study left behind: a network meta-analysis in non-small-cell lung cancer demonstrating the importance of considering all relevant data. *Value In Health: The Journal Of The International Society For Pharmacoeconomics And Outcomes Research* 2009 Sep;12(6):996-1003.
- (149) Hind D, Calvert N, McWilliams R, Davidson A, Paisley S, Beverley C, et al. Ultrasonic locating devices for central venous cannulation: meta-analysis. *BMJ (Clinical Research Ed)* 2003 Aug 16;327(7411):361.
- (150) Hochberg MC, Tracy JK, Hawkins-Holt M, Flores RH. Comparison of the efficacy of the tumour necrosis factor alpha blocking agents adalimumab, etanercept, and infliximab when added to methotrexate in patients with active rheumatoid arthritis. *Ann Rheum Dis* 2003 Nov;62 Suppl 2:ii13-ii16.
- (151) Hodson EM, Craig JC, Strippoli GF, Webster AC. Antiviral medications for preventing cytomegalovirus disease in solid organ transplant recipients. *Cochrane Database of Systematic Reviews* 2008 Jun;(2).
- (152) Hofmeyr GJ, Gülmezoglu AM, Novikova N, Linder V, Ferreira S, Piaggio G. Misoprostol to prevent and treat postpartum haemorrhage: a systematic review and meta-analysis of maternal deaths and dose-related effects. *Bulletin of the World Health Organization* 2009 Sep;87(9):666-F.
- (153) Holmes M, Carroll C, Papaioannou D. Dabigatran etexilate for the prevention of venous thromboembolism in patients undergoing elective hip and knee surgery: a single technology appraisal. *Health Technology Assessment* 2009 Feb;13:55-62.
- (154) Jansen JP. Self-monitoring of glucose in type 2 diabetes mellitus: a Bayesian meta-analysis of direct and indirect comparisons. *Curr Med Res Opin* 2006 Apr;22(4):671-81.
- (155) Jansen JP, Gaugris S, Choy EH, Ostor A, Nash JT, Stam W. Cost effectiveness of etoricoxib versus celecoxib and non-selective NSAIDs in the treatment of ankylosing spondylitis. *Pharmacoeconomics* 2010 Apr 1;28(4):323-44.
- (156) Jansen JP, Bergman GJD, Huels J, Olson M. Prevention of vertebral fractures in osteoporosis: mixed treatment comparison of bisphosphonate therapies. *Current Medical Research And Opinion* 2009 Aug;25(8):1861-8.
- (157) King S, Griffin S, Hodges Z, Weatherly H, Asseburg C, Richardson G, et al. A systematic review and economic model of the effectiveness and cost-effectiveness of methylphenidate, dexamfetamine and atomoxetine for the treatment of attention deficit hyperactivity disorder in children and adolescents. *Health Technology Assessment* 2006;10(23):iii.
- (158) Kulisevsky J, Pagonabarraga J. Tolerability and safety of ropinirole versus other dopamine agonists and levodopa in the treatment of Parkinson's disease: meta-analysis of randomized controlled trials. *Drug Safety: An International Journal Of Medical Toxicology And Drug Experience* 2010 Feb 1;33(2):147-61.
- (159) Lam SKH, Owen A. Combined resynchronisation and implantable defibrillator therapy in left ventricular dysfunction: Bayesian network meta-analysis of randomised controlled trials. *BMJ (Clinical Research Ed)* 2007 Nov 3;335(7626):925.
- (160) Lam SKH, Owen A. Is the finding of the PROFESS study consistent with predictions of network meta-analysis? *European Heart Journal* 2008 Oct;29(20):2580.
- (161) Lancaster T, Stead L. Physician advice for smoking cessation. *Cochrane Database Of Systematic Reviews (Online)* 2004;(4):CD000165.
- (162) Lee YH, Woo JH, Rho YH, Choi SJ, Ji JD, Song GG. Meta-analysis of the combination of TNF inhibitors plus MTX compared to MTX monotherapy, and the adjusted indirect comparison of TNF inhibitors in patients suffering from active rheumatoid arthritis. *Rheumatology International* 2008 Apr;28(6):553-9.
- (163) Lim E, Harris G, Patel A, Adachi I, Edmonds L, Song F. Preoperative versus postoperative chemotherapy in patients with resectable non-small cell lung cancer: Systematic review and indirect comparison meta-analysis of randomized trials [abstract no.7546]. *Journal of Clinical Oncology: ASCO annual meeting proceedings* 2008;26(15S part I):408.
- (164) Lim E, Ali Z, Ali A, Routledge T, Edmonds L, Altman DG, et al. Indirect comparison meta-analysis of aspirin therapy after coronary surgery. *BMJ (Clinical Research Ed)* 2003 Dec 6;327(7427):1309.
- (165) Lim E, Harris G, Patel A, Adachi I, Edmonds L, Song F. Preoperative versus postoperative chemotherapy in patients with resectable non-small cell lung cancer: systematic review and indirect comparison meta-analysis of randomized trials. *Journal Of Thoracic Oncology: Official Publication Of The International Association For The Study Of Lung Cancer* 2009 Nov;4(11):1380-8.
- (166) Loveman E, Turner D, Hartwell D, Cooper K, Clegg A. Infliximab for the treatment of adults with psoriasis. *Health Technology Assessment* 2009 Feb;13:55-60.

- (167) Manzoli L, Salanti G, De Vito C, Boccia A, Ioannidis JPA, Villari P. Immunogenicity and adverse events of avian influenza A H5N1 vaccine in healthy adults: multiple-treatments meta-analysis. *The Lancet Infectious Diseases* 2009 Aug;9(8):482-92.
- (168) Mason JB, Fehring TK, Estok R, Banel D, Fahrbach K. Meta-analysis of alignment outcomes in computer-assisted total knee arthroplasty surgery. *The Journal Of Arthroplasty* 2007 Dec;22(8):1097-106.
- (169) McLeod C, Bagust A, Boland A, Hockenhull J, Dundar Y, Proudlove C, et al. Erlotinib for the treatment of relapsed non-small cell lung cancer. *Health Technol Assess* 2009 Jun;13 Suppl 1:41-7.
- (170) Meader N. A comparison of methadone, buprenorphine and alpha(2) adrenergic agonists for opioid detoxification: a mixed treatment comparison meta-analysis. *Drug And Alcohol Dependence* 2010 Apr 1;108(1-2):110-4.
- (171) Mhaskar R, Redzepovic J, Wheatley K, Clark OA, Miladinovic B, Glasmacher A, et al. Bisphosphonates in multiple myeloma. *Cochrane Database Syst Rev* 2010;3:CD003188.
- (172) Mills EJ, Rachlis B, Wu P, Devereaux PJ, Arora P, Perri D. Primary prevention of cardiovascular mortality and events with statin treatments: a network meta-analysis involving more than 65,000 patients. *J Am Coll Cardiol* 2008 Nov 25;52(22):1769-81.
- (173) Mills EJ, Rachlis B, O'Regan C, Thabane L, Perri D. Metastatic renal cell cancer treatments: an indirect comparison meta-analysis. *BMC Cancer* 2009;9:34.
- (174) Mills EJ, Perri D, Cooper C, Nachega JB, Wu P, Tleyjeh I, et al. Antifungal treatment for invasive *Candida* infections: a mixed treatment comparison meta-analysis. *Annals Of Clinical Microbiology And Antimicrobials* 2009;8:23.
- (175) Moore RA, Derry S, McQuay HJ. Indirect comparison of interventions using published randomised trials: systematic review of PDE-5 inhibitors for erectile dysfunction. *BMC Urology* 2005;5:18.
- (176) Nixon R, Bansback N, Brennan A. The efficacy of inhibiting tumour necrosis factor alpha and interleukin 1 in patients with rheumatoid arthritis: a meta-analysis and adjusted indirect comparisons. *Rheumatology (Oxford)* 2007 Jul;46(7):1140-7.
- (177) Nixon RM, Bansback N, Brennan A. Using mixed treatment comparisons and meta-regression to perform indirect comparisons to estimate the efficacy of biologic treatments in rheumatoid arthritis. *Statistics In Medicine* 2007 Mar 15;26(6):1237-54.
- (178) Norris SL, Carson S, Roberts C. Comparative effectiveness of pioglitazone and rosiglitazone in type 2 diabetes, prediabetes, and the metabolic syndrome: a meta-analysis. *Current Diabetes Reviews* 2007 May;3(2):127-40.
- (179) Orme M, Collins S, Dakin H, Kelly S, Loftus J. Mixed treatment comparison and meta-regression of the efficacy and safety of prostaglandin analogues and comparators for primary open-angle glaucoma and ocular hypertension. *Current Medical Research And Opinion* 2010 Mar;26(3):511-28.
- (180) Perlis RH, Welge JA, Vornik LA, Hirschfeld RMA, Keck PEJ. Atypical antipsychotics in the treatment of mania: a meta-analysis of randomized, placebo-controlled trials. *The Journal Of Clinical Psychiatry* 2006 Apr;67(4):509-16.
- (181) Peterson K, McDonagh MS, Rongwei F. Comparative benefits and harms of competing medications for adults with attention-deficit hyperactivity disorder: a systematic review and indirect comparison meta-analysis. *Psychopharmacology* 2008 Mar 15;197(1):1-11.
- (182) Phung OJ, Scholle JM, Talwar M, Coleman CI. Effect of noninsulin antidiabetic drugs added to metformin therapy on glycemic control, weight gain, and hypoglycemia in type 2 diabetes. *JAMA: The Journal Of The American Medical Association* 2010 Apr 14;303(14):1410-8.
- (183) Piccini JP, Hasselblad V, Peterson ED, Washam JB, Califf RM, Kong DF. Comparative efficacy of dronedarone and amiodarone for the maintenance of sinus rhythm in patients with atrial fibrillation. *Journal Of The American College Of Cardiology* 2009 Sep 15;54(12):1089-95.
- (184) Psaty BM, Lumley T, Furberg CD, Schellenbaum G, Pahor M, Alderman MH, et al. Health outcomes associated with various antihypertensive therapies used as first-line agents: a network meta-analysis. *JAMA* 2003 May 21;289(19):2534-44.
- (185) Puhan MA, Bachmann LM, Kleijnen J, Ter Riet G, Kessels AG. Inhaled drugs to reduce exacerbations in patients with chronic obstructive pulmonary disease: a network meta-analysis. *BMC Medicine* 2009;7:2.
- (186) Purkayastha S, Athanasiou T, Tekkis PP, Constantinides V, Teare J, Darzi AW. Magnetic resonance colonography vs computed tomography colonography for the diagnosis of colorectal cancer: an indirect comparison. *Colorectal Disease: The Official Journal Of The Association Of Coloproctology Of Great Britain And Ireland* 2007 Feb;9(2):100-11.
- (187) Quilici S, Abrams KR, Nicolas A, Martin M, Petit C, Llieu PL, et al. Meta-analysis of the efficacy and tolerability of pramipexole versus ropinirole in the treatment of restless legs syndrome. *Sleep Medicine* 2008 Oct;9(7):715-26.
- (188) Quilici S, Chancellor J, Lwithgren M, Simon D, Said G+, Le TK, et al. Meta-analysis of duloxetine vs. pregabalin and gabapentin in the treatment of diabetic peripheral neuropathic pain. *BMC Neurology* 2009;9:6.
- (189) Raskob GE, Hirsh J. Controversies in timing of the first dose of anticoagulant prophylaxis against venous thromboembolism after major orthopedic surgery. *Chest* 2003 Dec;124(6 Suppl):379S-85S.
- (190) Rice VH, Stead LF. Nursing interventions for smoking cessation. *Cochrane Database Of Systematic Reviews (Online)* 2000;(2):CD001188.
- (191) Rice VH, Stead LF. Nursing interventions for smoking cessation. *Cochrane Database Of Systematic Reviews (Online)* 2001;(3):CD001188.

- (192) Richy F, Schacht E, Bruyere O, Ethgen O, Gourlay M, Reginster JY. Vitamin D analogs versus native vitamin D in preventing bone loss and osteoporosis-related fractures: a comparative meta-analysis. *Calcified Tissue International* 2005 Mar;76(3):176-86.
- (193) Richy FF, Banerjee S, Brabant Y, Helmers S. Levetiracetam extended release and levetiracetam immediate release as adjunctive treatment for partial-onset seizures: an indirect comparison of treatment-emergent adverse events using meta-analytic techniques. *Epilepsy & Behavior: E&B* 2009 Oct;16(2):240-5.
- (194) Salanti G, Higgins J, Marinho V. How to determine the best treatment: a mixed-treatment-comparisons meta-analysis (MTM) of trials of topical fluoride therapies for the prevention of dental caries [abstract]. XIII Cochrane Colloquium; 2005 Oct 22-26; Melbourne, Australia 2005;58.
- (195) Salanti G, Marinho V, Higgins JP. A case study of multiple-treatments meta-analysis demonstrates that covariates should be considered. *Journal Of Clinical Epidemiology* 2009;62(8):857-64.
- (196) Sanchez-Ramos L, Kaunitz AM, Delke I. Labor induction with 25 microg versus 50 microg intravaginal misoprostol: a systematic review. *Obstetrics And Gynecology* 2002 Jan;99(1):145-51.
- (197) Sauriol L, Laporta M, Edwardes MD, Deslandes M, Ricard N, Suissa S. Meta-analysis comparing newer antipsychotic drugs for the treatment of schizophrenia: evaluating the indirect approach. *Clin Ther* 2001 Jun;23(6):942-56.
- (198) Schneeweiss S, Maclure M, Carleton B, Glynn RJ, Avorn J. Clinical and economic consequences of a reimbursement restriction of nebulised respiratory therapy in adults: direct comparison of randomised and observational evaluations. *BMJ* 2004 Mar 6;328(7439):560.
- (199) Segal JB, McNamara RL, Miller MR, Kim N, Goodman SN, Powe NR, et al. Prevention of thromboembolism in atrial fibrillation. A meta-analysis of trials of anticoagulants and antiplatelet drugs. *Journal Of General Internal Medicine* 2000 Jan;15(1):56-67.
- (200) Segal JB, McNamara RL, Miller MR, Powe NR, Goodman SN, Robinson KA, et al. Anticoagulants or antiplatelet therapy for non-rheumatic atrial fibrillation and flutter. *Cochrane Database Syst Rev* 2001;(1):CD001938.
- (201) Silagy C. Physician advice for smoking cessation. *Cochrane Database Of Systematic Reviews (Online)* 2000;(2):CD000165.
- (202) Singh JA, Christensen R, Wells GA, Suarez-Almazor ME, Buchbinder R, Lopez-Olivo MA, et al. Biologics for rheumatoid arthritis: an overview of Cochrane reviews. *Cochrane Database of Systematic Reviews* 2009 Dec;(4).
- (203) Singh JA, Christensen R, Wells GA, Suarez-Almazor ME, Buchbinder R, Lopez-Olivo MA, et al. A network meta-analysis of randomized controlled trials of biologics for rheumatoid arthritis: a Cochrane overview. *CMAJ: Canadian Medical Association Journal* 2009 Nov 24;181(11):787-96.
- (204) Singh JA. Biologics for rheumatoid arthritis: an overview of Cochrane reviews. *Cochrane Database of Systematic Reviews* 2010 Mar 16;(4).
- (205) Snick HK, Collins JA, Evers JL. What is the most valid comparison treatment in trials of intrauterine insemination, timed or uninfluenced intercourse? A systematic review and meta-analysis of indirect evidence. *Hum Reprod* 2008 Oct;23(10):2239-45.
- (206) Snyman JR, Wessels F. Perindopril: do randomised, controlled trials support an ACE inhibitor class effect? A meta-analysis of clinical trials. *Cardiovascular Journal Of Africa* 2009 Mar;20(2):127-34.
- (207) Stead LF, Bergson G, Lancaster T. Physician advice for smoking cessation. *Cochrane Database of Systematic Reviews* 2008 Jun;(2).
- (208) Stettler C, Allemann S, Egger M, Windecker S, Meier B, Diem P. Efficacy of drug eluting stents in patients with and without diabetes mellitus: indirect comparison of controlled trials. *Heart* 2006 May;92(5):650-7.
- (209) Stettler C, Wandel S, Allemann S, Kastrati A, Morice MC, Schömig A, et al. Outcomes associated with drug-eluting and bare-metal stents: a collaborative network meta-analysis. *Lancet* 2007 Sep 15;370(9591):937-48.
- (210) Stettler C, Allemann S, Wandel S, Kastrati A, Morice MC, Schömig A, et al. Drug eluting and bare metal stents in people with and without diabetes: collaborative network meta-analysis. *BMJ* 2008;337:a1331.
- (211) Stevenson M, Jones ML, De Nigris E, Brewer N, Davis S, Oakley J. A systematic review and economic evaluation of alendronate, etidronate, risedronate, raloxifene and teriparatide for the prevention and treatment of postmenopausal osteoporosis. *Health Technology Assessment (Winchester, England)* 2005 Jun;9(22):1-160.
- (212) Strassmann R, Bausch B, Spaar A, Kleijnen J, Braendli O, Puhan MA. Smoking cessation interventions in COPD: a network meta-analysis of randomised trials. *The European Respiratory Journal: Official Journal Of The European Society For Clinical Respiratory Physiology* 2009 Sep;34(3):634-40.
- (213) Strippoli GF, Bonifati C, Craig M, Navaneethan SD, Craig JC. Angiotensin converting enzyme inhibitors and angiotensin II receptor antagonists for preventing the progression of diabetic kidney disease. *Cochrane Database Syst Rev* 2006;(4):CD006257.
- (214) Sultana A, Ghaneh P, Cunningham D, Starling N, Neoptolemos JP, Smith CT. Gemcitabine based combination chemotherapy in advanced pancreatic cancer-indirect comparison. *BMC Cancer* 2008;8:192.
- (215) Thijs V, Lemmens R, Fieuws S. Network meta-analysis: simultaneous meta-analysis of common antiplatelet regimens after transient ischaemic attack or stroke. *European Heart Journal* 2008 May;29(9):1086-92.
- (216) Thompson Coon JS, Liu Z, Hoyle M, Rogers G, Green C, Moxham T, et al. Sunitinib and bevacizumab for first-line treatment of metastatic renal cell carcinoma: a systematic review and indirect comparison of clinical effectiveness. *British Journal Of Cancer* 2009 Jul 21;101(2):238-43.

- (217) Trikalinos TA, sheikh-Ali AA, Tatsioni A, Nallamothu BK, Kent DM. Percutaneous coronary interventions for non-acute coronary artery disease: a quantitative 20-year synopsis and a network meta-analysis. *Lancet* 2009 Mar 14;373(9667):911-8.
- (218) Tu Y, Woolston A, Faggion CM, Jr. Do bone grafts or barrier membranes provide additional treatment effects for infrabony lesions treated with enamel matrix derivatives? A network meta-analysis of randomized-controlled trials. *Journal Of Clinical Periodontology* 2010;37(1):59-79.
- (219) Turner D, Picot J, Cooper K, Loveman E. Adalimumab for the treatment of psoriasis. *Health Technology Assessment* 2009 Feb;13:49-54.
- (220) Uthman OA, Abdulmalik J. Comparative efficacy and acceptability of pharmacotherapeutic agents for anxiety disorders in children and adolescents: a mixed treatment comparison meta-analysis. *Current Medical Research And Opinion* 2010 Jan;26(1):53-9.
- (221) van der Valk R, Webers CAB, Lumley T, Hendrikse F, Prins MH, Schouten JSAG. A network meta-analysis combined direct and indirect comparisons between glaucoma drugs to rank effectiveness in lowering intraocular pressure. *Journal Of Clinical Epidemiology* 2009 Dec;62(12):1279-83.
- (222) van Pinxteren B, Numans ME, Bonis PA, Lau J. Short-term treatment with proton pump inhibitors, H2-receptor antagonists and prokinetics for gastro-oesophageal reflux disease-like symptoms and endoscopy negative reflux disease. *Cochrane Database Of Systematic Reviews (Online)* 2000;(2):CD002095.
- (223) van Pinxteren B, Numans ME, Bonis PA, Lau J. Short-term treatment with proton pump inhibitors, H2-receptor antagonists and prokinetics for gastro-oesophageal reflux disease-like symptoms and endoscopy negative reflux disease. *Cochrane Database Of Systematic Reviews (Online)* 2001;(4):CD002095.
- (224) van Pinxteren B, Sigterman KE, Bonis P, Lau J, Numans ME. Short-term treatment with proton pump inhibitors, H2-receptor antagonists and prokinetics for gastro-oesophageal reflux disease-like symptoms and endoscopy negative reflux disease. *Cochrane Database of Systematic Reviews* 2006 Sep;(3).
- (225) van Pinxteren, Numans ME, Bonis PA, Lau J. Short-term treatment with proton pump inhibitors, H2-receptor antagonists and prokinetics for gastro-oesophageal reflux disease-like symptoms and endoscopy negative reflux disease. *Cochrane Database Syst Rev* 2004;(4):CD002095.
- (226) Vandermeer BW, Buscemi N, Liang Y, Witmans M. Comparison of meta-analytic results of indirect, direct, and combined comparisons of drugs for chronic insomnia in adults: a case study. *Medical Care* 2007 Oct;45(10 Suppl 2):S166-S172.
- (227) Vis PM, van Baardewijk M, Einarson TR. Duloxetine and venlafaxine-XR in the treatment of major depressive disorder: a meta-analysis of randomized clinical trials. *The Annals Of Pharmacotherapy* 2005 Nov;39(11):1798-807.
- (228) Walsh T, Worthington HV, Glenny AM, Appelbe P, Marinho VC, Shi X. Fluoride toothpastes of different concentrations for preventing dental caries in children and adolescents. *Cochrane Database Syst Rev* 2010;(1):CD007868.
- (229) Wehren LE, Hosking D, Hochberg MC. Putting evidence-based medicine into clinical practice: comparing anti-resorptive agents for the treatment of osteoporosis. *Current Medical Research And Opinion* 2004 Apr;20(4):525-31.
- (230) Welton NJ, Cooper NJ, Ades AE, Lu G, Sutton AJ. Mixed treatment comparison with multiple outcomes reported inconsistently across trials: evaluation of antivirals for treatment of influenza A and B. *Statistics In Medicine* 2008 Nov 29;27(27):5620-39.
- (231) Welton NJ, Caldwell DM, Adamopoulos E, Vedhara K. Mixed treatment comparison meta-analysis of complex interventions: psychological interventions in coronary heart disease. *American Journal of Epidemiology* 2009 May 1;169(9):1158-65.
- (232) Woolacott N, Hawkins N, Mason A, Kainth A, Khadjesari Z, Bravo Vergel Y, et al. Etanercept and efalizumab for the treatment of psoriasis: a systematic review. *Health Technology Assessment* 2006;10(46):1-252.
- (233) Yazdanpanah Y, Sissoko D, Egger M, Mouton Y, Zwahlen M, Chene G. Clinical efficacy of antiretroviral combination therapy based on protease inhibitors or non-nucleoside analogue reverse transcriptase inhibitors: indirect comparison of controlled trials. *BMJ* 2004 Jan 31;328(7434):249.
- (234) Zhou Z, Rahme E, Pilote L. Are statins created equal? Evidence from randomized trials of pravastatin, simvastatin, and atorvastatin for cardiovascular disease prevention. *American Heart Journal* 2006 Feb;151(2):273-81.